

Ercoupe MEMORANDUM

ERCOUPE
SERVICE
MEMORANDUM

No. **35**

SUBJECT: Rigging

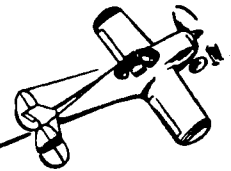

Revised 1-6-06

The procedure outlined below is suggested for use in rigging or making adjustments to the rigging of the Ercoupe.

Before beginning the actual rigging of the air-plane, the load should be taken from the nose wheel by weighting the tail to hold it in a depressed attitude.

1. Secure control wheels in neutral position (center spoke vertical). This can be checked by placing a straight-edge beneath the control wheels - if all four lower points of the two control wheels contact the straight-edge, the wheels are properly adjusted. Any necessary corrections should be made by adjustment of the turnbuckles between the sprockets of the control wheels. In making these adjustments, care must be exercised so that upon completion, the center line of the quadrant (on top of control assembly) is aligned with the longitudinal axis of the airplane. Safety turnbuckles (as per Sketch A) per FAA AC 43.13-1B or later revision. In this connection, care must be exercised that all turnbuckles are completely free of sprockets, in all positions (see para. 3, Service Department Bulletin No. 13).

2. Verify the position of the control mast in neutral (located below the baggage compartment). The longer arms should be trammed, using as points (1) the center of the bolts attaching the control rods (415-52038) and (2) the center of the rear attaching bolts of the mast support casting (415-52057). The control wheel and the mast centering is synchronized by adjusting the connecting push-pull rod (415-52036). To install or remove the AN3-10 clevis bolt, which connects the push-pull rod and control mast, remove the AN4-16 bolt in the short arm and rotate the arm to clear the clevis bolt. Tighten the locknuts of the control rod and safety all nuts after any adjustments.

3. Check rudder bellcrank (415-52424) in the stabilizer for neutral position. This is accomplished by measuring the distance between the forward face of the stabilizer rear beam and the rudder push-pull rods

(415-52022) adjacent to their attachment to the bellcrank. Both sides should be equal.

4. Verify that rudder cables cross in the middle of tailcone per figure 13 of the Ercoupe Service Manual. Adjust the rudder control cables to neutralize if out of line. Cables should have 60 lb.-70 lb. tension after adjusting. Safety turnbuckles (as per Sketch A) per FAA AC 43.13-1B or later revision.

5. Establish a center line for checking the rudder adjustment, using as a center the mid point between the stabilizer forward attaching bolts. Extend a line from this point at 90° to trailing edge of elevator.

6. Check the setting of the rudders with the control system still in neutral. Trailing edge of both rudders should be equidistant from the reference line established in paragraph 5 above. As a double check, the distance should be 49 3/4". (Any error is corrected by adjustment of the affected rudder push-pull rod). Tighten lock-nuts and safety all bolts.

7. Verify the position of the aileron bellcrank on the outboard ribs of the center section. The distance from the centers of the attaching bolt holes in the arm and the front face of the rear spar should be 7-11/16". This distance must be the same on both sides. (Any error is corrected by adjusting the push-pull rods, 415-52038). (All adjustments on these rods must be made on the rod-end adjacent to the control mast because of the inaccessibility of the locknut at the aileron bellcrank.)

8. Check aileron for droop. Both ailerons should fair with center section trailing edge. Necessary adjustment is made on push-pull rod (415-52034). Should a slight amount of warpage prevent aileron from fairing at the outboard edge, this can be disregarded as correction for this condition will be made after flight test. (See para. 13.)

9. Verify nose wheel alignment by sighting from rear of plane. Adjust push-pull rod

(415-52035) as necessary. After adjustment, tighten lock-nuts and safety ball-socket joint. (In the near future, a new and improved push-pull rod will be installed which will permit adjustment adjacent to the nose wheel and will obviate the necessity of removing the floorboards as must now be done.) Free control wheels (see step 1). Final check is made by taxiing the airplane holding control wheel in neutral. After gaining momentum for taxi run, power should be cut so that while actual test is being made, no power is being applied. Aircraft should hold straight course. *NOTE:* Taxi run should be made with up-wind or down-wind and over as flat and smooth a surface as is available.

10. On rudder, lay out line perpendicular to the trailing edge of the vertical stabilizer from a point 15/16" above the lower-forward attaching bolt of the center hinge and running to the trailing edge of the rudder (see sketch B). From the intersection of this line and the trailing edge of the rudder, measure 3 1/4" upwards and at this height and 1/4" forward of the trailing edge, drill a No. 57 hole which can be used as a reference hole for upward travel of the elevator. (Elevator up-travel is specified at 13'). Allowable tolerance is + 1/4". Down travel should be 12' but its exact value is not important.

NOTE: On Ercoupe Serial No. 2123 and subsequent, a reference hole as described above has been drilled on the inboard skin only.

11. Using reference hole established in para-graph 10 above, check the elevator up-travel by moving the control wheel to the full aft position as limited by the stop on the control wheel shaft. (Any error is corrected by adjustment of the elevator control cables.) Tension on the cables should be 160 lb.-190 lb. as measured on a tensionmeter. Safety turnbuckles (as per Sketch A) per FAA AC 43.13-1B or later revision.

12. After thorough inspection of all safetying, etc., as made above, aircraft is ready for flight test.

13. If after thorough flight test, wing heaviness exists, check over carefully steps 1 through 8 above. If controls are properly aligned, the extreme trailing edge of the aileron may be used as a fixed trim tab and bent with suitable metal bending pliers. When making use of the aileron trailing edge in this manner, any bending must be begun at the outboard end of the wing opposite the

heavy wing and the bending must always be done downward. The amount of bending and the length of the area bent will vary with the amount of wing heaviness present. In any case, only the extreme trailing edge of the aileron (the flat section containing the rivets) should be bent only a very slight amount. A slight bend over a greater length is preferable to a pronounced bend over a small length. As a guide in bending the trailing edge of the aileron, it has been determined that wing heaviness necessitating a 5' deflection of the control wheel from neutral to hold the airplane on course in flight can be corrected by a 3/16" downward bend for the full length of the trailing edge of the aileron.

14. Adjustment of longitudinal trim device is covered in Service Memorandum No. 19, for Ercoupes previous to No. 1623, and Service Memorandum No. 25 for Ercoupes subsequent to No. 1623.

15. Effective about Ercoupe No. 3882, the elevator trailing edge has been bent downward 3' on production aircraft. It was found that this modification makes it easier to bring the airplane within the desired glide characteristics. (See Service Memorandum No. 19.)

Note:
Refer to section 10 of FAA AC43.13-1B
(or later revision) for optional turn buckle
safetying methods.

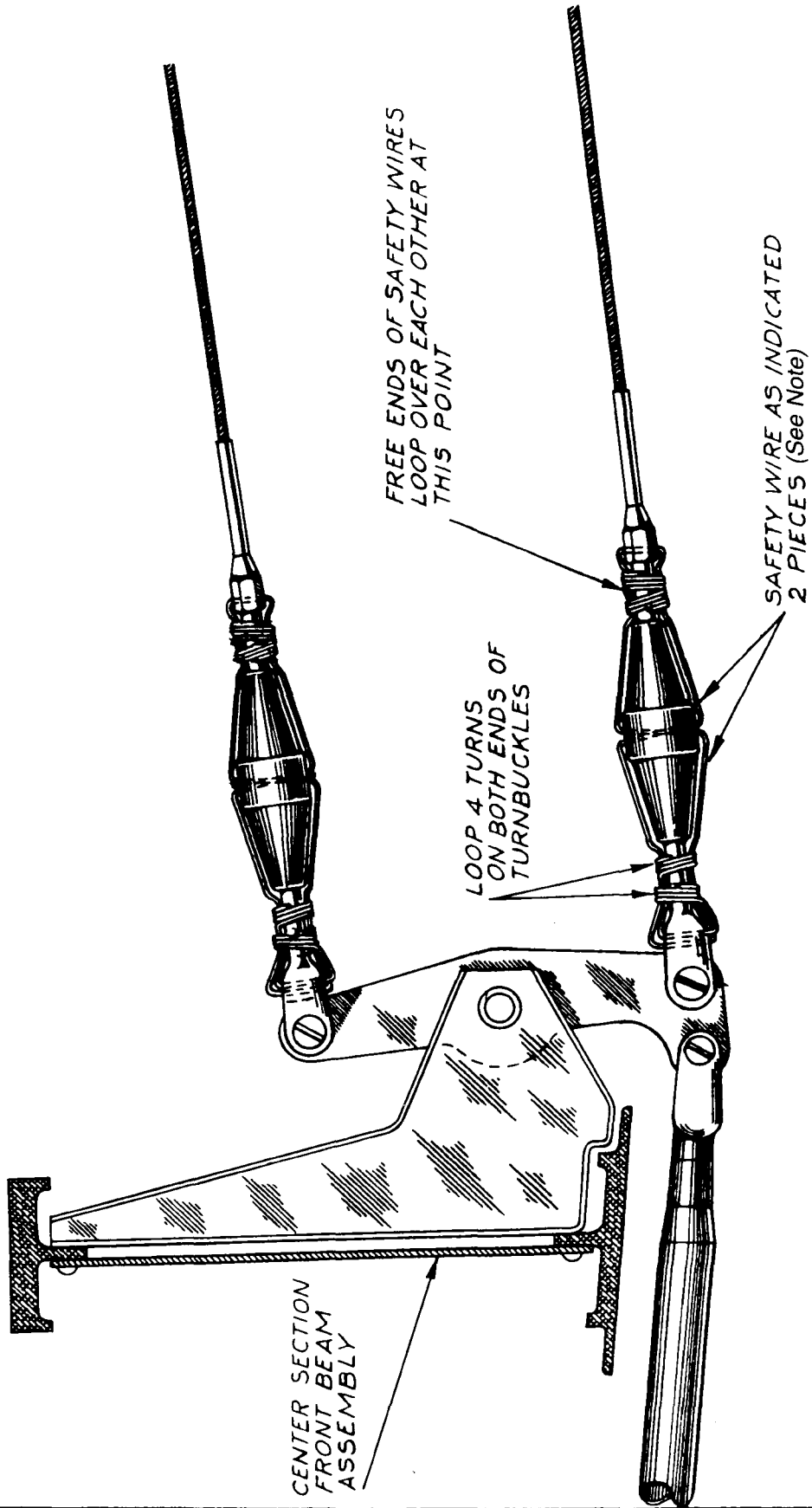

SKETCH A
Revised 1-3-06

**SAFETY WIRING OF
ELEVATOR TURNBUCKLES**

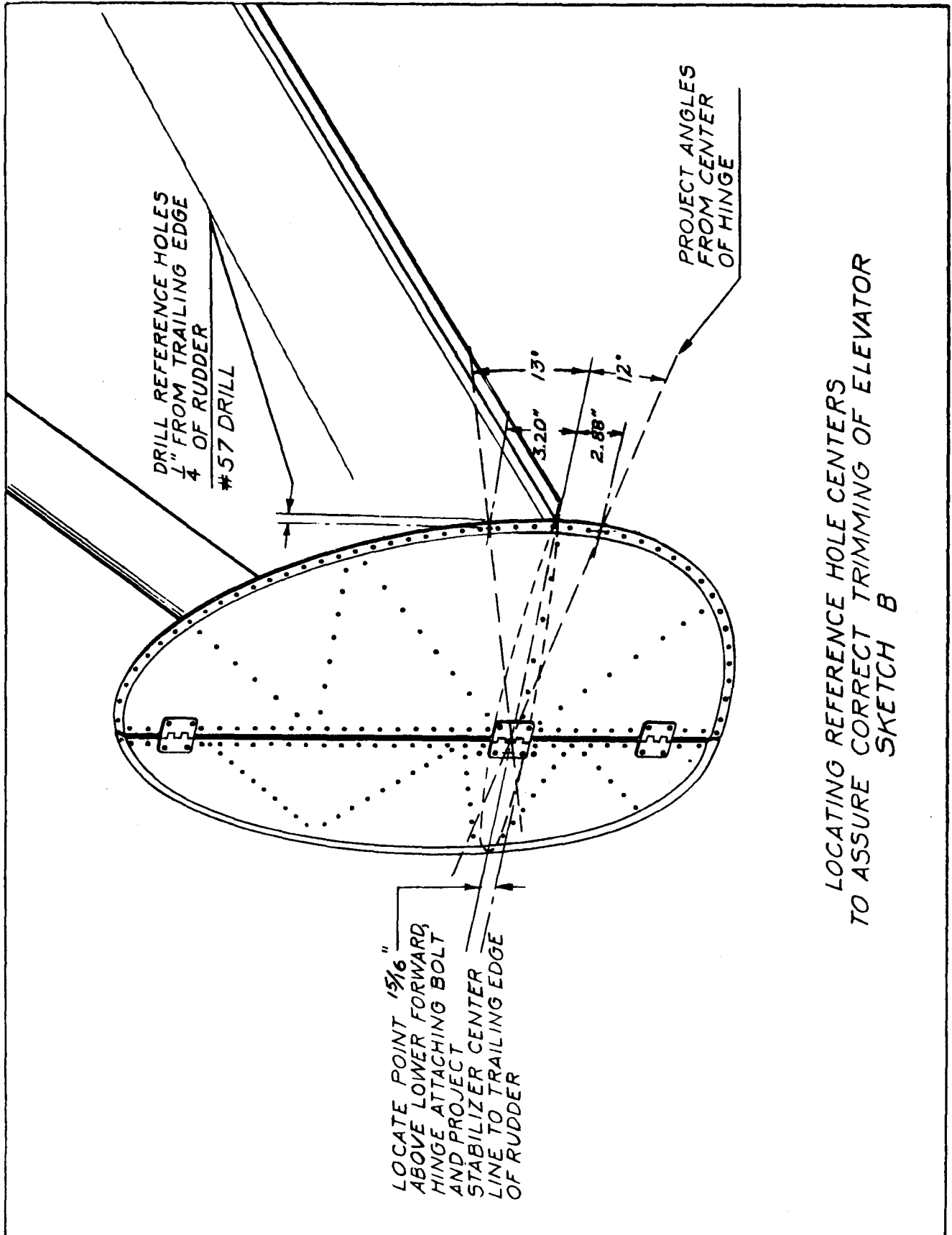

LOCATING REFERENCE HOLE CENTERS
TO ASSURE CORRECT TRIMMING OF ELEVATOR
SKETCH B