

ENGINE • FUEL SYSTEM

CONTENTS

Air Filters.....	163	Gaskets	176
B&C Specialty Products	169	Lubricant.....	177
Carburetors	170	Lycoming Engine Parts.....	177
Continental Engine Parts.....	173	Magnetos.....	177
Drain Valves	174	Manuals	179
Franklin Engine Parts	175	Oil Filters.....	180
Fuel Pumps	175	Shielded Ignition Leads.....	181
Fuel Tank Accessories	176	Spark Plugs	186
Fuel Valves	176	Throttle Controls	191
Gascolators.....	176		

Air Filters

• Brackett filters are FAA/PMA approved and STC-SA71GL, STC-SA693CE, and STC-SA12CE approved



Polyurethane as the filtering media combined with Brackett's patented "wetting agent" will give your engine protection from dust and dirt to prolong engine life and cut maintenance. The Brackett polyurethane aircraft element can be changed without replacing the complete air filter assembly. Now induction systems, cylinders, and combustion chambers can be kept almost totally free of harmful contaminants with correct fitting of Brackett aviation air filters.



Brackett Air Filter Application Chart

Aircraft Make and Models	Brackett Filter Assembly		Filter Gasket		Brackett Element	
	Part #	Price	Part #	Price	Part #	Price
■ AERO COMMANDER						
A-9, A9A, A9B	BA-104	\$29.63	—	—	BA-3	\$15.35
100, 100A	BA-8910	\$93.92	—	—	BA-8905	\$10.58
100, 180	BA-3910	\$68.54	—	—	BA-3905	\$15.26
112, 112A, 112B	BA-3910	\$68.54	—	—	BA-3905	\$15.26
112TC, 112TC-A, 114, 114A	BA-4010	\$75.99	—	—	BA-4005	\$16.25
500	BA-152	\$84.30	—	—	BA-152E	\$20.18
580, 580A, 560E, 680	BA-2610-L/R	\$77.60	—	—	BA-2605-L/R	\$18.56
■ AIRCOUPE						
415C, CD, D, E, G	BA-8810	\$48.42	—	—	BA-8805	\$9.29
F-1, A-1, A2-2	BA-4106	\$62.01	BA-4101	\$5.13	BA-4108	\$8.51

ENGINE • FUEL SYSTEM

Aircraft Make and Models	Brackett Filter Assembly		Filter Gasket		Brackett Element	
	Part #	Price	Part #	Price	Part #	Price
■ BEECH						
23, A23, A23A, A23-19, A23-19A, A23-24, B23	BA-104	\$29.63	—	—	BA-3	\$15.35
C-23, C24R, A24R, B24R, B19	BA-7510	\$71.57	BA-7504	\$7.92	BA-7305	\$13.80
33, A33, B33, C33, E33, F33	BA-7110	\$74.25	BA-7104	\$10.58	BA-7112	\$14.90
C33A, E33A, E33C, F33A, F33C, G33	BA-7210	\$74.25	BA-7206	\$7.92	BA-7112	\$14.90
35, A35, B35 through SN D2605	BA-7310	\$71.39	BA-7303	\$6.48	BA-7305	\$13.80
B35, C35, D35, E35, F35, G35, H35, J35, K35, M35, N35, P35, 35R	BA-7110	\$74.25	BA-7104	\$10.58	BA-7112	\$14.90
S35 through SN D7671	BA-7410	\$74.25	BA-7406	\$7.92	BA-7112	\$14.90
S35, V35, V35A, V35B, 36, A36, A36TC, B36TC, A45 (T-34), B45 (T-34A), D45 (T-34B), W/STC SA1450SW CONT IO-520	BA-7210	\$74.25	BA-7206	\$7.92	BA-7112	\$14.90
50, B50, C50, D50, D50A, D50B, D50C, D50E	—	—	—	—	BA-4805	\$19.29
E50 (L-23D, RL-23D), F50, G50, H50, J50	BA-100	\$103.80	BA-1003	\$10.59	BA-7	\$19.61
55, A55, B55	BA-7610	\$75.78	BA-7603	\$4.20	BA-7605	\$15.72
C55, D55, E55, E55A (SN TE768-1078), 58 (through SN TH740)	BA-6210-1	\$70.47	—	—	BA-6205	\$14.46
E55, E55A (SN TE1079 and up), 58, 58A (SN TH741 and up)	BA-7710	\$75.15	BA-7703	\$8.90	BA-7705	\$17.34
A65, 70, 65-B80, B88	BA-100	\$103.80	BA-1003	\$10.59	BA-7	\$19.61
76	BA-7010	\$70.47	—	—	—	—
77	BA-2010	\$63.32	—	—	BA-6108	\$9.95
95, B95, B95A, D95A	BA-7810	\$73.77	—	—	BA-7805	\$16.76
■ BELL						
47G-2, 2A, 2A1, 3, 3B, 3B-1, 3B-2, 3B-2A; 47J, 47J-2, 47J-2A	BA-102	\$37.04	—	—	BA-2	\$19.88
47G-3B, 3B-1, 3B-2, 4, 4A, 5; 47J-2, 2A	BA-103	\$58.13	—	—	BA-9	\$25.07
■ BELLANCA						
14-19-3A	BA-8110	\$85.76	BA-8101	\$11.16	BA-8103-1	\$18.59
17-30	BA-8110	\$85.76	—	—	BA-8103-1	\$18.59
17-30A	BA-104	\$29.63	—	—	BA-3	\$15.35
■ BRANTLEY						
B-2, B-2B	BA-104	\$29.63	—	—	BA-3	\$15.35
■ BRITTEN NORMAN						
BN-2A-6 with Lycoming O-540-E4C5 engines, BN-2, 2A, 2A-2, 2A-3, 2A-8, 2A-9, 2A-20, 2A-21, 2A-27, 2B-20, 2B-21, 2B-26, 2B-27	BA-104	\$29.63	—	—	BA-3	\$15.35
■ CESSNA						
120, 140, 140A, 150, 150A, B, C, D, E, F, G, H, J, K, L, M, A150M, 152, A152, F150G, H, J, K, L, M, FA150K, L, F152, FA152	BA-4106	\$62.01	BA-4101	\$5.13	BA-4108	\$8.51
170, 170A, B, 172, 172A, B, C, D, E, F, G, H, I, K, L, M, F172D, E, F, G, H, K, L, M	BA-5110	\$66.05	BA-5103	\$4.77	BA-6108	\$9.95
172-N, P, F172N, P	BA-5110A	\$67.91	BA-5103	\$4.77	BA-6108	\$9.95
R172K, FR172E, F, G, H, J, K	BA-111	\$80.42	—	—	BA-24	\$18.68

Aircraft Make and Models	Brackett Filter Assembly		Filter Gasket		Brackett Element	
	Part #	Price	Part #	Price	Part #	Price
172RG	BA-5810	\$82.47	BA-5803	\$5.60	—	—
175, 175A, B, C	BA-101	\$88.64	BA-1102	\$13.26	BA-8	\$12.17
177, 177A, B, RG, F177RG	BA-5710	\$89.99	BA-5703	\$10.58	BA-5705	\$11.33
180 (1953-1955)	BA-8010	\$75.29	BA-8002	\$10.58	BA-8005	\$12.60
180A, B, C, D, E, F, G, H, J, K	BA-8110	\$85.76	BA-8101	\$11.16	BA-8103-1	\$18.59
182, 182A, B, C, D, E, F, G, H, J, K, L, M, N, P, Q, R, F182P, Q	BA-8110	\$85.76	BA-8101	\$11.16	BA-8103-1	\$18.59
R-182, TR-182, T-182, FR182	BA-2510	\$81.80	BA-2503	\$10.43	BA-2505	\$20.61
185, 185A, B, C, D, E, A185E, A185F	BA-8110	\$85.76	BA-8101	\$11.16	BA-8103-1	\$18.59
188, 188A	BA-114	\$79.86	—	—	BA-14A	\$18.08
190, 195, 195A, B	BA-8410	\$96.39	—	—	BA-8405	\$28.68
205, 205A	BA-2110	\$91.61	BA-2103	\$13.07	BA-2305	\$18.24
P206, A, B, C, D, E, U206, A, B, C, D, E, F, G	BA-2210L	\$91.61	BA-2206	\$10.01	BA-2205L	\$20.60
TP206A, B, C, D, E, TU206A, B, C, D, E, F, G	BA-2410	\$93.09	—	—	BA-2405	\$34.07
207, 207A	BA-2210L	\$91.61	BA-2206	\$10.01	BA-2205L	\$20.60
T207, T207A	BA-2410	\$93.09	—	—	BA-2405	\$34.07
210, 210A, B, C	BA-2110	\$91.61	BA-2103	\$13.07	BA-2305	\$18.24
210D, E, F, G, H, J, K, L, M, N (to SN 64535 without AIR)	BA-2210L BA-2210R	\$91.61 \$91.61	BA-2206 BA-2206	\$10.01 \$10.01	BA-2205L BA-2205R	\$20.60 \$20.60
210N (SN 64536 and up with AIR), 210R	BA-2410	\$93.09	—	—	BA-2405	\$34.07
P210, all	BA-8710	\$99.74	—	—	BA-8705	\$18.02
T-210F, G, H, J, K, L, M, N	BA-2410	\$93.09	—	—	BA-2405	\$34.07
T-303	BA-5210	\$81.80	BA-2503	\$10.43	BA-5205	\$20.56
310, A, B	BA-2110	\$91.61	BA-2103	\$13.07	BA-2305	\$18.24
310F, G, H, I, J, K, L	BA-2310	\$91.61	BA-2303	\$12.44	BA-2305	\$18.24
310N, P, Q, T310P, T310Q	BA-107	\$72.84	—	—	BA-12	\$24.06
310R	BA-117	\$79.29	—	—	BA-17	\$24.33
T310R	BA-108	\$76.40	—	—	BA-13	\$26.45
336	BA-111	\$80.42	—	—	BA-24	\$18.68
337, A, B, C, D, E, F, G, H, F337E, F, G, H	BA-111	\$80.42	—	—	BA-24	\$18.68
P337, T337 rear engine	BA-5810	\$82.47	—	—	—	—
340, 340A	BA-109	\$64.32	—	—	BA-22	\$24.02
401 (SN 145 to 402B SN 221)	BA-107	\$72.84	—	—	BA-12	\$24.06
402, (SN 145 to 402B SN 800)	BA-107	\$72.84	—	—	BA-12	\$24.06
402B (SN 801 and up)	BA-108	\$76.40	—	—	BA-13	\$26.45
402C	BA-109	\$64.32	—	—	BA-22	\$24.02
404	BA-130	\$71.25	—	—	BA-30	\$26.67
411, 411A	BA-3810	\$77.73	—	—	BA-3805	\$21.29
414, 414A	BA-109	\$64.32	—	—	BA-22	\$24.02
421, 421A, B, C	BA-108	\$76.40	—	—	BA-13	\$26.45
L-19	BA-101	\$88.64	BA-1102	\$13.26	BA-8	\$12.17
T41B, C, D	BA-111	\$80.42	—	—	BA-24	\$18.68
T-50, AT-17, UC-78, JRC-1	BA-2710	\$98.63	—	—	BA-2705	\$22.52

ENGINE • FUEL SYSTEM

Aircraft Make and Models	Brackett Filter Assembly		Filter Gasket		Brackett Element	
	Part #	Price	Part #	Price	Part #	Price
■ CHAMPION						
8KCAB, 8GCBC, 7KCAB, 7GCBC, 7GCAA	BA-8110	\$85.76	BA-8101	\$11.16	BA-8103-1	\$18.59
7GCAA, 7GCBC, 7KCAB, 8KCAB, 7ECA	BA-106	\$31.67	—	—	BA-11	\$13.55
7GC, 7GCA, 7GCBC, 7GCB	BA-104	\$29.63	—	—	BA-3	\$15.35
7HC, 7KC	BA-104	\$29.63	—	—	BA-3	\$15.35
7ECA with Continental O-200-A engine, 7ACA, 7ECA, 7FC, 65CA	BA-4106	\$62.01	BA-4101	\$5.13	BA-4108	\$8.51
■ DE HAVILLAND						
DHC-2 (L-20)	BA-8210-1	\$112.49	BA-8208	\$5.39	BA-8205	\$30.96
■ GREAT LAKES						
2TIA-2	BA-101	\$88.64	BA-1102	\$13.26	BA-8	\$12.17
■ GRUMMAN AMERICAN						
AA-1, AA-1A, AA-1B, AA-1C, AA-5	BA-4210	\$61.37	BA-4101	\$5.13	BA-4108	\$8.51
AA5A	—	—	—	—	BA-19	\$12.77
AA5B Tiger, GA-7	BA-120	\$31.11	—	—	BA-20	\$17.60
Agcat G164, G164A	BA-8210	\$102.81	BA-8101	\$11.16	BA-8205	\$30.96
G164B	BA-105	\$36.15	—	—	BA-10	\$19.74
■ HILLER						
UH-12, UH-12A, B, C, D, E	BA-102	\$37.04	—	—	BA-2	\$19.88
■ HELIO						
H295	—	—	—	—	BA-21	\$30.20
■ HUGHES						
269A, A-1, B, C	BA-102	\$37.04	—	—	BA-2	\$19.88
■ LAKE						
LA4, LA4-200	BA-3110	\$72.03	BA-3103	\$4.83	BA-7305	\$13.80
■ LUSCOMBE						
8, 8A through 8F, T8F	BA-4106	\$62.01	BA-4101	\$5.13	BA-4108	\$8.51
■ MAULE						
M-4-210, 210C, 210S, 210T, M-5-210C	BA-111	\$80.42	—	—	BA-24	\$18.68
MA-4, M-4C, 4S, 4T, 4-220, 4-220C, 4-220S, 4-220T, 4-180C, 4-180S, 4-180T, M-5-220C, 235C, 180C, 210TC, M-6-180, 235, MX7- 180, M-7-235	BA-6110	\$76.58	BA-5103	\$4.77	BA-6108	\$9.95
■ MOONEY						
M-10	BA-4106	\$62.01	BA-4101	\$5.13	BA-4108	\$8.51
M-18C	BA-5110	\$66.05	BA-5103	\$4.77	BA-6108	\$9.95
M20, M20A, B, C, D, G	BA-6110	\$76.58	BA-5103	\$4.77	BA-6108	\$9.95
M20E, F	BA-6310	\$70.47	—	—	BA-6305	\$18.69
M20J	BA-6210	\$70.47	BA-6203	\$13.26	BA-6205	\$14.46
■ NAVION						
B, G, H	BA-4310	\$65.82	BA-4303	\$6.68	BA-4305	\$11.96
A	BA-113	\$49.88	—	—	BA-25	\$17.48
B with Lycoming G0-435 engine	BA-116	\$52.13	—	—	BA-26	\$17.79

Aircraft Make and Models	Brackett Filter Assembly		Filter Gasket		Brackett Element	
	Part #	Price	Part #	Price	Part #	Price
■ NORTH AMERICAN						
AT6 (SNJ)	BA-8310	\$359.18	—	—	BA-8305	\$59.96
■ PIPER						
600, 601	—	—	—	—	BA-4	\$32.73
J-3, J-4, J-5	BA-4106	\$62.01	BA-4101	\$5.13	BA-4108	\$8.51
PA-11, 11S, 12, 12S	BA-4106	\$62.01	BA-4101	\$5.13	BA-4108	\$8.51
PA-16, 17, 18, 19	BA-4106	\$62.01	BA-4101	\$5.13	BA-4108	\$8.51
PA-18-150, PA-18A-150, PA-18S-150, PA-18AS-150 SN 18-6964 and up, with TCDS item 110 installed	BA-112	\$65.34	—	—	BA-13	\$26.45
PA-20, 115 and 135hp	BA-4106	\$62.01	BA-4101	\$5.13	BA-4108	\$8.51
PA-22, all	BA-4106	\$62.01	BA-4101	\$5.13	BA-4108	\$8.51
PA-23, 160hp	BA-3110A	\$72.03	—	—	BA-7305	\$13.80
PA-23, 235 and 250hp	BA-104	\$29.63	—	—	BA-3	\$15.35
PA-23-250, PA-E23-250 SN 27-2505 and up	BA-115	\$41.40	—	—	BA-15	\$17.79
PA-23-250, PA-E23-250 with turbo Lycoming engine	BA-3510	\$92.64	—	—	BA-3505	\$19.16
PA-24-180 up to SN 1476	BA-3110A	\$72.03	—	—	BA-7305	\$13.80
PA-24-250 up to SN 1476	BA-3210	\$77.27	—	—	BA-3205	\$15.72
PA-24, 180 and 250hp SN 1477 and up, PA-24-250 SN 103 to 1476 with Piper kit 754-285 installed, PA-24-260 SN 4000 to 4802 except 4783	BA-104	\$29.63	—	—	BA-3	\$15.35
PA-24-260C	BA-4510	\$76.61	—	—	BA-4505	\$16.16
PA-25, 235 and 260hp	BA-104	\$29.63	—	—	BA-3	\$15.35
PA-28-140, 150, 160, 180, 235	BA-104	\$29.63	—	—	BA-3	\$15.35
PA-28-181, 201T	BA-104	\$29.63	—	—	BA-3	\$15.35
PA-28R-201T	BA-104	\$29.63	—	—	BA-3	\$15.35
PA-28RT-201T	BA-104	\$29.63	—	—	BA-3	\$15.35
PA-28R-201, PA-28RT-201, PA-28R-180, PA-28R-200	BA-105	\$36.15	—	—	BA-10	\$19.74
PA-28-151, 161	—	—	—	—	BA-16	\$9.72
PA-28-236 SN 7911283 and up	BA-2910	\$65.75	—	—	BA-2905	\$14.27
PA-30-160	BA-105	\$36.15	—	—	BA-10	\$19.74
PA-31, PA-31-300, -310, -325, -350	BA-100	\$103.80	BA-1003	\$10.59	BA-7	\$19.61
PA-31P, PA-31P-350	BA-3310	\$153.08	—	—	BA-3305	\$24.08
PA-32-260	BA-104	\$29.63	—	—	BA-3	\$15.35
PA-32-300 SN 76-40001 and up, PA-32R-300, PA-32RT-300, PA-32R-301	BA-104	\$29.63	—	—	BA-3	\$15.35
PA-32-300 with IO-540-K1A5	BA-115	\$41.40	—	—	BA-15	\$17.79
PA-32RT-300T	BA-100	\$103.80	BA-1003	\$10.59	BA-7	\$19.61
PA-32-301T, PA-32R-301T	BA-3010	\$83.45	—	—	BA-7	\$19.61
PA-34-200T, 220T	BA-104	\$29.63	—	—	BA-3	\$15.35

ENGINE • FUEL SYSTEM

Aircraft Make and Models	Brackett Filter Assembly		Filter Gasket		Brackett Element	
	Part #	Price	Part #	Price	Part #	Price
PA-34-200 with Lycoming IO-360-C01E6 or LIO-360-C1E6	BA-105	\$36.15	—	—	BA-10	\$19.74
PA-36-300 with Continental 6-285-B, PA-36-375	BA-104	\$29.63	—	—	BA-3	\$15.35
PA-38	BA-4106	\$62.01	BA-4101	\$5.13	BA-4108	\$8.51
PA-39	BA-105	\$36.15	—	—	BA-10	\$19.74
PA-44-180	BA-105	\$36.15	—	—	BA-10	\$19.74
PA-44-180T	BA-3510	\$92.64	—	—	BA-3505	\$19.16
■ ROBINSON						
R-22	BA-110	\$31.22	—	—	BA-23	\$18.68
■ STEARMAN						
All series 75	BA-118	\$69.57	—	—	BA-18	\$32.06
■ STINSON						
108, 108-1, 2, 3	BA-9110	\$42.36	—	—	BA-9105	\$11.25
■ SWIFT						
GC-1A, GC-1B	BA-4106	\$62.01	BA-4101	\$5.13	BA-4108	\$8.51
■ TAYLORCRAFT						
All models	BA-4106	\$62.01	BA-4101	\$5.13	BA-4108	\$8.51
■ VARGA						
2150A	BA-4106	\$62.01	BA-4101	\$5.13	BA-4108	\$8.51



Air-Maze Air Filters – Original Paper Type

Univair supplies a wide variety of air filters for light planes. Protect yourself and your engine by replacing your air filter regularly.

Piper PA-18 Air Filters

- *Applicability: Piper PA-18, PA-18A 150hp models, SN 18-6964 and up*
- *FAA/PMA approved*

Air Filter U454-118 **\$45.84**



- *Applicability: Piper PA-18, 135hp and 150hp models*
- *Also for seaplanes*

Air Filter (460-638) 120086 **\$48.38**

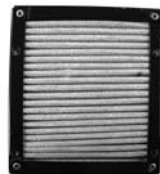

Piper PA-22 Air Filter

- *Applicability: Piper PA-22 108hp, 135hp, 150hp and 160hp*

Air Filter (13681) 121494 **\$140.87**



Franklin and Stinson Air Filter

- *Applicability: Franklin 150-165hp engines and Stinson 108 series*
- *Close out strip sold separately*

Air Filter 108-6221805 **\$69.73**

Close Out Strip 108-6221805-8 **\$20.12**



Aeronca Air Filter

- *Applicability: Aeronca 7AC and 11AC*

Air Filter U2-849 **\$105.19**

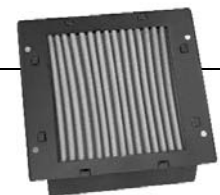

Ercoupe Air Filter

- *Applicability: Continental C-75 and C-85, Ercoupe*

Air Filter 415-40585-1 **\$87.73**



Air-Maze Air Filter

- *Applicability:* Continental engines A-65, A-75, C-85, C-90, and C-125; Luscombe 8A through 8F, Taylorcraft, Cessna 140, Swift GC-1A and GC-1B, etc.; Piper J-3 through J-5, PA-11, PA-15, PA-17, PA-18 (90hp, 105hp, 125hp models) and PA-22 (125hp models)
- Use with UA50256 housing
- Prior to use, oil by dipping in Grade 1 or Grade 2 of MIL-L-21260, and allow to drain for 2 to 4 hours; wipe off excess oil

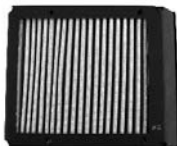

Air Filter (40599).....	600314.....	\$79.35
Stud	24306.....	\$9.77
Cross Pin (24308)	652021.....	\$24.42
Gasket.....	652142.....	\$7.87
Fastener on box (531050)	99871C098.....	\$5.52

Piper PA-23 Apache Air Filter

- *Applicability:* O-320 Lycoming engine in Piper Apache

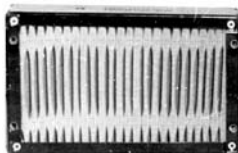

Air Filter	17775-000.....	\$110.81
------------------	----------------	-----------------

Carburetor Air Boxes for 4-Cylinder Continental Engines



- *Applicability:* C75-8, C75-8F, C75-12, C75-12F, C85-8, C85-8F, C85-12, C85-12F, C90-8F, C90-12F engines

UA50256	\$595.22
---------------	-----------------



- *Applicability:* A65-1, A65-3, A65-6, A65-7, A65-8, A65-8F, A65-9, A65-9F, A65-12, A65-12F, A65-14, A65-14F engines

UA50495	\$595.24
---------------	-----------------

Carburetor Air Intake Box and Filter



- Complete assembly for the Aeronca

7AC-11AC Air Box (Includes Air Filter)	U4-601-1.....	\$686.38
Filter Only	U2-849.....	\$105.19



Continental Carburetor Air Intake Support Assembly

Continental Bracket.....	UA35917.....	\$95.93
--------------------------	--------------	----------------



J-3 Cowl Bracket Nut Adapter for C-85.....	23130.....	\$84.35
--	------------	----------------



B&C Specialty Products

B&C Oil Filter Adapter

The original 90° oil filter adapter! Mounts directly on the accessory case to replace the OEM oil screen, the horizontal mount AC-brand oil filter adapter, or other "remote" oil filtration systems (with no complicated hoses and leak-proof fittings). Ships ready to install, with new mounting hardware, gasket, and a Champion 48108-1 filter.



- *Exceptional strength* – CNC machined from a solid billet of aluminum (not a casting)
- No hoses or fittings
- Weighs only 2.25 lbs with CH48108-1 filter
- Available with 3 sizes of billet aluminum spacers
- STC/PMA: Lycoming O-235 to IO-720

Oil Filter Adapter.....	BC700-1.....	\$450.00
-------------------------	--------------	-----------------

B&C Primary Alternator Systems for PA-18

- STC/PMA for Piper PA-18 and PA-19
- Includes BC201-1 Regulator

With a rated output of 40 amps, and weighing just 6.1 lbs, the BC400-2 features a precision-balanced rotor, sealed heavy duty ball bearings, three solid attach points, two built-in cooling fans, and provision for modern, aircraft-appropriate external regulation. Ships with mounting brackets (for either Wide or Narrow-Deck mount engines), attach hardware, belt tension arm, and belt.



NOTE: This approved installation applies to aircraft with previously existing electrical systems, and oil coolers mounted on the aft engine baffle only. Aircraft otherwise equipped will require field alteration and FAA approval.

Alternator, with Regulator BC201-1.....	BC400-2.....	\$698.00
---	--------------	-----------------

B&C Lycoming Replacement Starter

The B&C Starter uses only sealed heavy-duty ball bearings, all-metal gears (no plastic gears of any kind), and an efficient series-wound motor.



- *Electromechanical pinion actuation* (no Bendix drive)
- *Weight:* 10.2 lbs.
- *Number of Ring Gear Teeth:* 122 or 149
- STC/PMA: Lycoming O-235 to IO-720

12-volt Starter, 122 Ring Gear Teeth	BC315-100-1.....	\$580.00
12-volt Starter, 149 Ring Gear Teeth	BC315-100-2.....	\$580.00
24-volt Starter, 149 Ring Gear Teeth	BC315-100-4.....	\$610.00

B&C Continental Replacement Starter

Featuring the durability of all-steel gears and heavy duty sealed ball bearings, and the efficiency of a high-torque series-wound motor, the B&C Starter for Continental engines provides for greater starting torque, while saving 4.3 to 5.2 lbs. over the old key-type and pull-cable type starters, respectively.



- Includes kit 501-1 for existing key type starters or 501-3 for existing pull-cable type starter
- Billet aluminum end bell
- Electromechanical pinion actuation
- Weight: 10.3 lbs.
- STC/PMA: Continental C-75, C-85, C-90, C-145, O-200, IO-240, O-300-A, -B, -C, and GO-300-A, -B, -C

12-volt Starter with Kit 501-1 (Key Type).....	BC320-1-1	\$608.00
12-volt Starter with Kit 501-3 (Pull-Cable Type)	BC320-1-3	\$618.00
Continental Starter Install Kit (Key Type)	FK501-1	\$25.00
Continental Starter Install Kit (Pull-Cable Type)	FK501-3	\$60.00

Carburetors

Bendix Stromberg Carburetor NA-S3A1 Assembly

#	Description	Part #	Quantity	Price
8	Nut, #10-32	AN315-3	1	\$0.14
9	Flat Washer	NAS1149F0363P	1	\$0.04
10	Cover Assembly, Mixture Control	P61037	1	\$62.83
13	Gasket, Mixture Control Cover	P61033	1	\$8.16
14	Gasket.....	384667	1	\$6.12
15	Stem, Mixture Control.....	P61034	1	\$78.96
17	Plate, Mixture Control Valve, Upper	P61030	1	\$74.10
18	Plate, Mixture Control Valve, Lower	P61031	1	\$90.02
19	Screw, #8-32 by 3/8 inch.....	AN505-8-6	1	NLA
20	Gasket.....	P61035	1	\$6.12
30	Pin, Split Taper #4/0.....	P21267-1	AR	\$0.93
41	Screw, Fillister Head 1/4-20 by 3/8 inch	P6550	6	\$3.75
46	Gasket.....	P16155	1	\$5.97
47	Plug (Bendix P8505).....	MS20913-2D	1	\$8.58
51	Pin, Fulcrum.....	P16160	1	\$1.91
54	Needle, Float (390077)	2523047	1	\$309.00
56	Gasket, 1/2 inch thick.....	P12999	1	\$5.74
	Gasket, 3/8 inch thick*	P16165	1	\$6.12
	Gasket, 3/4 inch thick*	P16166	1	\$6.12
	Gasket, 1/2 inch thick*	P16167	1	\$6.12
60	Gasket, Copper.....	1745-22	1	\$14.56
69	Gasket.....	P5329	1	\$2.67
70	Gasket.....	P2885	1	\$6.12
	Gasket Kit (Not Illustrated)	380189		\$102.34

* When necessary to change the float level, one of these gaskets may be used under the float needle seat in place of P12999

Exploded View

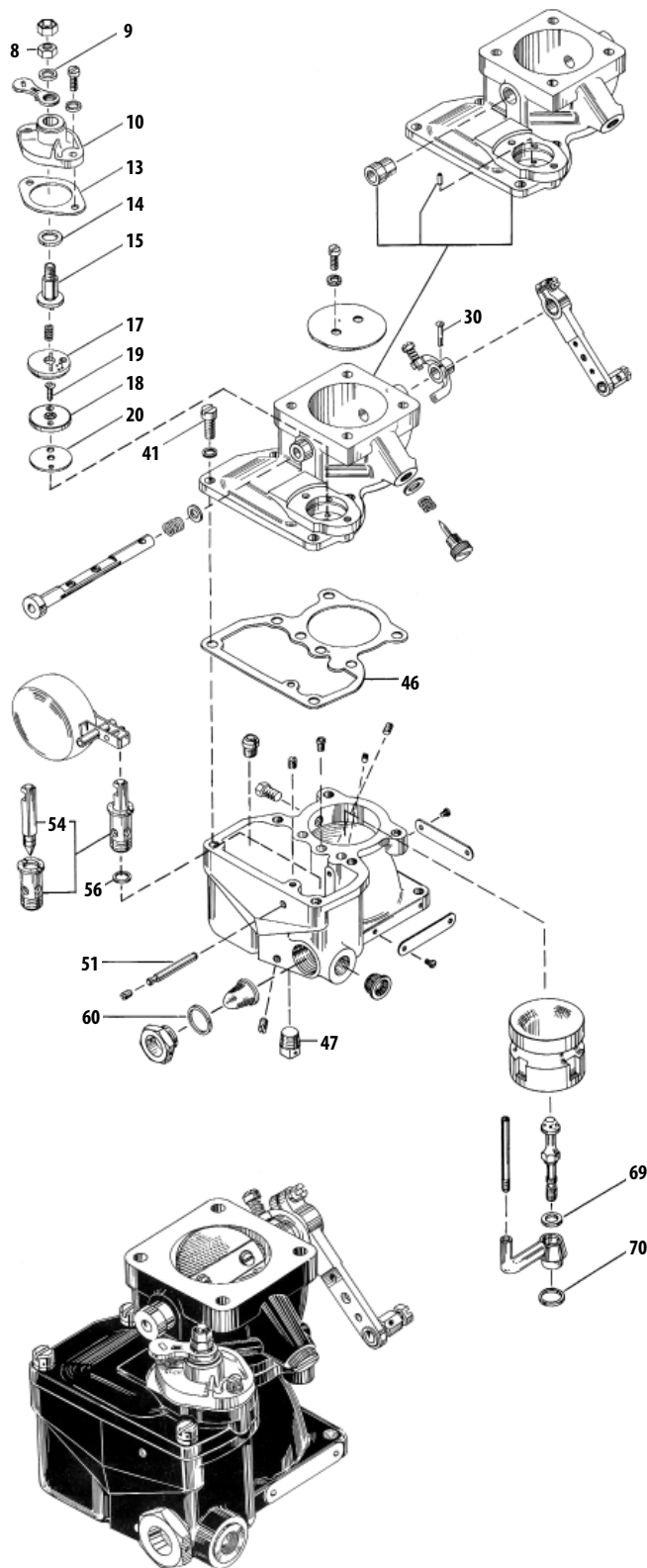

Precision Carburetor Parts • Price list on next page

Carburetor Part #	Pump	Shaft	Nozzle	Idle Tube	Float	Float Shaft	Float Valve	Float Setting	Idle Needle	Gaskets	Repair Kit
A10-2065	—	—	—	—	—	A32-32	—	7/32	A43-564	A16-599	*
A10-2065-P	—	—	—	—	—	A32-32	—	7/32	A43-564	A16-599	*
A10-2301	A194-580	A13-853	A47-613	—	—	A32-35	A233-614	13/64	—	—	*
A10-2535-1	A194-580	—	—	—	A30-766	A32-32	—	7/32	A43-564	A16-630	*
A10-2827	—	A13-853	—	A229-560	—	A32-35	A233-614	13/64	—	A16-646	*
A10-2848	A194-593	—	A47-652	A229-566	A30-766	A32-32	—	7/32	A43-564	A16-CF-653	A286-1629
A10-2948	—	—	—	A229-541	A30-766	A32-32	—	7/32	A43-564	A16-CF-653	A286-815
A10-2971	A194-593	—	—	A229-569	A30-766	A32-32	—	7/32	A43-564	A16-CF-653	*
A10-2971-P	A194-593	—	—	A229-569	A30-766	A32-32	—	7/32	A43-564	A16-CF-653	*
A10-2983	—	—	A47-667	A229-567	A30-766	A32-32	—	7/32	A43-564	—	*
A10-3148-1	A194-580	A13-853	A47-689	A229-572	—	A32-35	A233-614	13/64	—	A16-625	*
A10-3237	A194-593	—	A47-702	A229-566	A30-766	A32-32	—	7/32	A43-564	CF16-653	A286-974
A10-3323	A194-580	A13-853	—	A229-560	—	A32-35	A233-614	13/64	—	A16-646	*
A10-3346-1	A194-593	—	A47-719	A229-569	A30-766	A32-32	—	7/32	A43-564	CF16-653	—
A10-3565-1	A194-593	—	A47-728	A229-569	A30-766	A32-32	—	7/32	A43-564	CF16-653	A286-1630
A10-3634	A194-580	—	A47-738	—	—	A32-35	A233-614	13/64	—	A16-625	*
A10-3649-1	A194-580	A13-853	—	A229-572	—	A32-35	A233-614	13/64	—	A16-625	*
A10-3678-12	CF194-581	—	—	A229-587	A30-766	A32-32	—	7/32	A43-564	CF16-676	*
A10-3678-32	CF194-581	—	A47-773	A229-587	A30-766	A32-32	—	7/32	A43-564	CF16-676	—
A10-3729	A194-593	—	A47-719	A229-569	A30-766	A32-32	—	7/32	A43-564	CF16-653	A286-1070
A10-3759	A194-580	A13-853	—	A229-572	—	A32-35	A233-614	13/64	—	A16-625	*
A10-3859	A194-580	A13-853	—	A229-572	—	A32-35	A233-614	13/64	—	A16-625	A286-939
A10-3859-1	A194-580	—	—	A229-572	—	A32-35	A233-614	13/64	—	A16-625	—
A10-3878	—	—	—	A229-590	—	A32-35	A233-614	13/64	—	A16-625	—
A10-3965-12	A194-580	A13-853	A47-749	A229-584	—	A32-35	A233-614	13/64	—	A16-625	—
A10-4115	A194-593	—	—	A229-587	—	A32-32	—	7/32	A43-564	—	—
A10-4164-1	—	—	A47-755	A229-589	—	A32-35	A233-614	13/64	A43-649	A16-625	*
A10-4171	A194-580	—	—	A229-584	—	A32-35	A233-614	13/64	—	A16-646	*
A10-4191	A194-580	A13-853	A47-749	A229-584	—	A32-35	A233-614	13/64	—	A16-625	*
A10-4218-1	—	—	—	—	—	A32-35	A233-614	13/64	—	A16-710	—
A10-4233	A194-593	—	—	A229-594	A30-766	A32-32	—	7/32	A43-564	—	—
A10-4240	A194-593	—	—	A229-587	A30-766	A32-32	—	7/32	A43-564	—	—
A10-4252	A194-593	—	—	A229-587	A30-766	A32-32	—	7/32	A43-564	—	A286-1632
A10-4404-1	—	—	A47-779	A229-592	—	A32-35	A233-614	13/64	—	A16-646	A286-1643
A10-4439	A194-593	—	A47-702	A229-566	A30-766	A32-32	—	7/32	A43-564	A16-653	*
A10-4457	A194-593	—	—	A229-587	A30-766	A32-32	—	7/32	A43-564	—	*
A10-4495	A194-580	—	—	—	A30-762	A32-35	A233-614	13/64	—	—	A286-1398

Use your Marvel-Schebler Parts and Service Manual for correct parts selection.

*Repair Kits for these carburetors are not available.

Prices for Precision Carburetors Parts

See applicability chart on previous page.

Pump

A194-580.....	\$62.98
A194-593.....	\$122.51
CF194-581.....	\$110.00

Shaft

A13-853.....	\$241.09
--------------	-----------------

Nozzle

A47-613.....	\$155.92
A47-652.....	\$115.38
A47-667.....	\$131.59
A47-689.....	\$155.92
A47-702.....	\$122.19
A47-719.....	\$62.98
A47-728.....	\$112.36
A47-738.....	\$233.21
A47-749.....	\$157.21
A47-755.....	\$233.21
A47-773.....	\$351.40
A47-779.....	\$255.98

Idle Tube

A229-541.....	\$81.03
A229-560.....	\$105.33
A229-566.....	\$104.26
A229-567.....	\$103.13
A229-569.....	\$88.70
A229-572.....	\$138.70
A229-584.....	\$132.74
A229-587.....	\$109.44
A229-589.....	\$90.84
A229-590.....	\$90.84
A229-592.....	\$90.84
A229-594.....	\$92.82

Float Shaft

A32-32.....	\$24.31
A32-35.....	\$20.83

Float Valve

A233-614.....	\$130.66
---------------	-----------------

Idle Needle

A43-564.....	\$44.88
A43-649.....	\$112.54

Gaskets

A16-625.....	\$108.20
A16-630.....	\$45.99
A16-646.....	\$111.84
A16-710.....	\$88.03

Repair Kit

A286-815.....	\$352.94
A286-939.....	\$557.90
A286-1070.....	\$388.87
A286-1398.....	\$721.73
A286-1629.....	\$660.00
A286-1630.....	\$728.48
A286-1632.....	\$660.00
A286-1643.....	\$784.03

Precision Replacement Parts

Available while supplies last

Description	Part #	Price
Screw.....	A15-A15.....	\$15.41
Screw.....	A15-A23.....	\$4.32
Screw.....	A15-483.....	\$3.83
Gasket.....	A16-A32.....	\$6.28
Gasket.....	A16-221.....	\$12.79
Rod.....	A17-383.....	\$30.11
Spring.....	A24-A10.....	\$8.05
Spring.....	A24-A39.....	\$5.94
Clip.....	A29-113.....	\$8.23
Plug.....	A37-4.....	\$0.90
Plug.....	A37-7.....	\$2.83
Packing.....	A44-86.....	\$12.25
Nozzle.....	A47-719.....	\$62.98
Nozzle.....	A47-728.....	\$112.36
Washer.....	A78-5.....	\$1.29
Washer.....	A78-121.....	\$4.50

Washer.....	A78-356.....	\$1.71
Washer.....	A78-357.....	\$1.85
Washer.....	A78-371.....	\$3.04
Plug.....	A80-151.....	\$37.87
Cotter Key.....	A82-14.....	\$2.51
Pipe Plug.....	A99-8.....	\$19.47
Tube Assembly.....	A229-560.....	\$105.33
Tube Assembly.....	A229-569.....	\$88.70
Tube Assembly.....	A229-579.....	\$61.29
Tube Assembly.....	A229-587.....	\$109.44
Tube Assembly.....	A229-588.....	\$88.70
Valve.....	A242-505.....	\$155.92
Valve.....	A242-508.....	\$167.75
Valve.....	A242-520.....	\$144.71
Valve.....	A242-528.....	\$138.01
Valve.....	A242-537.....	\$50.15
Long Lock Kit.....	A666-652.....	\$169.08

Marvel Repair Kits



A286-815

(not all included parts are shown)

Carburetor Part #	Part #	Price
A10-3168.....	A286-815.....	\$352.94
A10-3859.....	A286-939.....	\$557.90
A10-3565-1.....	A286-1630.....	\$728.48
A10-3729.....	A286-1070.....	\$388.87
A10-3634.....	A286-1190.....	\$532.37
A10-4495.....	A286-1428.....	\$674.41
A10-4240.....	A286-1428.....	\$674.41

Shop online at www.univair.com

View our full line of aircraft parts and supplies on our website.

Continental Engine Parts

Commonly Requested Continental Parts for C-Series and O-200 Engines

Cylinder Base Seals for A6-5-75, C-75-85-90, O-200.....	21477	\$0.95
Intake Gaskets		
A-65-75	649976	\$1.42
C-75-85-90, O-200 (22250).....	649975	\$2.81
Crankshaft Seal		
Flanged Shaft for A-65-75, C-75-85-900, O-200	530019	\$60.61
Tapered Shaft for A-65-75, C-75-85.....	24321	\$65.10
Tach Seal for A-65-75, C-75-85-90, O-200	642714	\$8.96
Oil Sump Gasket for A-65-75, C-75-85-90, O-200.....	652248	\$5.64
Rocker Cover Gasket		
For A-65-75, C-75-85-90, O-200 (653728)	655706	\$6.16
Carb to Intake Gasket for A-65 to C-90, O-200 (21051).....	652105	\$2.65
Carb to Airbox Gasket for A-65 to C-90, O-200	649974	\$2.46
Intake Hose Small for A-65 to C-90, O-200	21185	\$4.89
Intake Hose Large for A-65 to C-90, O-200.....	22800	\$5.08
Pushrod Housing Gasket for A-65 to C-90, O-200		
(not used on -8 and -8f).....	649952	\$5.00
Connector Pushrod Housing		
For A-65-75, C-75-85-90, O-200.....	539840	\$6.54
Gasket Oil Screen for A-65-75, C-75-85-90, O-200.....	MS35769-48	\$0.70
Gasket Oil Screen Housing Plug		
For A-65-75, C-75-85-90, O-200.....	MS35769-11	\$0.72

Continental AC Pump Adapter Kit

Complies with AD 81-07-06 Teledyne Continental Motors, which applies to A-65, A-75, C-75, C-85, C-90, A-100, C-125, and O-200 engines equipped with AC fuel pumps, part numbers 40585, 40695 or 631391.

Pump Adapter Kit.....AF-6561 **\$151.23**

Kit consists of the following parts:

Screen.....	643913
Gasket.....	643914
Screw.....	643915

Mounting Components for C-90-14F and O-200

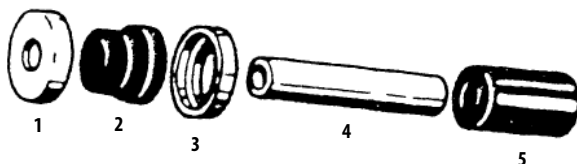

- *Priced and sold individually*

1) Washer • 8 required.....	530741	\$6.93
2) Bushing • 8 required	530740	\$39.03
3) Seat • 8 required	530626	\$20.38
4) Spacer • 4 required.....	653695	\$29.53
5) Hose • 4 required	628555-16	\$9.39

Carburetor Induction Manifolds

For A-65, C-75, C-85, C-90	U35145	\$359.60
For O-200	U35145-A1	\$477.48



Continental Engine Mount Bushings

- Used on all A and C series Continental engines
- Rubber
- 8 required per installation
- Priced and sold individually



Engine Mount Bushings..... U22387A **\$5.21**

Surplus Continental Rocker Cover Gaskets

- *Applicability: Continental A-65, A-75, C-85, C-90, O-200, C-145, O-300 engines*
- *Supersedes part number 3500*

Rocker Cover Gasket..... 530162S **\$1.53**



Exhaust Gaskets

- *New stainless steel exhaust gaskets*
- *Applicability: Continental engines*
- *2 required per port (sold individually)*

Exhaust Gaskets..... 632837 **\$3.13**



Blo-Proof Spiral Wound Gaskets

- *V-shaped spirals wound with layers of stainless steel*

For Continental engines A-65; C-85; C-90; O-200; O-300; GO-300; E-185; E-225; O-470-A, -E, -J; and IO-470-J, -K..... 652459 **\$13.44**



For all Continental O-470 and IO-470 series engines: TSIO-470-B; TSIO-520-B, -C; GTSIO-520-C, -D (excluding O-470-A, -E, -J and IO-470-J, -K) 652458 **\$10.49**

Don't see what you need?
Univair's knowledgeable sales staff is here to help.

Toll Free Sales: 1-888-433-5433

Info Phone: 303-375-8882

Fax: 800-457-7811 or 303-375-8888

email: info@univair.com

Business Hours:

Monday-Friday • 7:30 a.m. – 5:00 p.m. MT

Order online at www.univair.com

Drain Valves

SAF-AIR Quick Drain Valves



Models CAV-110 and CAV-110H-4

For Cessna 310 tip tanks, Mooney Mark 20 and 20A; all Ercoupe models, Bellanca, Taylorcraft Model B, Stinson 108, 108-1, 108-2, 108-3; Voyager Model 10 and 10A, Navion, Waco VK series and UPF, Sea Bee, and all aircraft with 1/8 NPT fuel outlets. Fits all standard gascolators. CAV-110H-4 comes with 1/4" hose end.

Models CAV-160 and CAV-160H-4

For Piper models J-3, J-4, PA-11, -12, -14, -15, -16, -17, -18, -20, -22, -23, -25; Apache, Champion, Aeronca, Cessna T-50 and earlier 120 and 140 models, Beechcraft AT-11 and C-18S, and all aircraft with 1/4 NPT fuel outlets. CAV-160H-4 comes with 1/4" hose end.

Models CAV-170 and CAV-170H-4

For all Cessna late 140A models, 150, 170, 170A, 170B, 172 and 175, and all aircraft with 7/16 inch 20 threaded fuel outlets. CAV-170H-4 comes with 1/4" hose end.

Models CAV-180 and CAV-180H-4

For Cessna 180, 182, 190, 195, 205, 210, 310, 310A, 310B, 310C, and 336, and all aircraft with 3/8 inch 24 threaded fuel outlets. CAV-180H-4 comes with 1/4" hose end.

Part #	Thread Size	Hose End	Price
CAV-110	1/8 NPT	none	\$18.12
22179-000 (CAV-110H-4)	1/8 NPT	1/4 inch	\$27.61
CAV-160	1/4 NPT	none	\$20.00
CAV-160H-4	1/4 NPT	1/4 inch	\$24.02
CAV-170	7/16-20 NF-3	none	\$20.02
CAV-170H-4	7/16-20 NF-3	1/4 inch	\$17.43
CAV-180	3/8-24 NF-3	none	\$22.85
CAV-180H-4	3/8-24 NF-3	1/4 inch	\$17.43

Replacement Seals (Fuel-Resistant O-Rings)

Tip (all models)	MS29513-006	\$0.30
Seat (180)	MS29513-011	\$0.68
Seat (170)	MS29513-012	\$0.18

Toll Free Sales: 1-888-433-5433

Monday-Friday 7:30 a.m. – 5:00 p.m. MT

Curtis Drain Valves

Quick opening brass drain valves for aircraft oil or fuel systems. A slight twist opens the valve. No safety wire is needed in the closed position. FAA approved for use without safety wire. Stainless steel spring holds valve in closed position. Valve has synthetic rubber seal suitable for temperatures up to 225°F.



Part #	Thread Size	Material	Slot	Price
CCA-1550	1/8 NPT	Brass	Straight	\$14.40
CCA-1600	1/4 NPT	Brass	Straight	\$16.11
CCA-1650	3/8 NPT	Brass	Straight	\$19.74
CCA-1700	1/2 NPT	Brass	Straight	\$29.50
CCA-4300	7/16-20 NF-3	Cadmium Plated	Spiral	\$22.59
CCA-4850	1/8 NPT	Cadmium Plated	Spiral	\$16.80

Fuel Drain Valves from MDI Aerovalve, Inc.

F391 Series Fuel Drain Valves

The MDI F391 flush valve is used as original equipment by most aircraft manufacturers and has been FAA/PMA approved for replacement parts. Listed below are the part numbers of the F391 valves and the aircraft they are approved for.



- A) Drain Valve – 1/4 inch taper pipe fitting F391-14 **\$27.05**
For Cessna T-50, Piper PA-11, -12, -18, -20, -22 or aircraft with 1/4 inch taper pipe fitting
- B) Drain Valve – 1/8 inch taper pipe fitting F391-18 **\$25.51**
For Maule aircraft M-5 (210 engine), M-5 (235 engine), M-5 (180 engine), M-5 (210-23 turbo-charged engine) or aircraft with 1/8 inch taper pipe fitting
- C) Drain Valve – 3/8 inch 24 thread F391-32 **\$24.23**
For Cessna 180, 182, 185, 188, 206, 207 or aircraft with 3/8 inch 24 threaded fitting (Cessna part #S2106-1)
- D) Drain Valve – 7/16 inch 20 thread F391-53S **\$24.37**
For Mooney M20J (201) and M20K (231) or aircraft with 7/16 inch 20 threaded fitting
- E) Drain Valve – 7/16 inch 20 thread F391-72 **\$25.38**
For Cessna 152, 172, 180, 185, 210 or aircraft with 7/16 inch 20 threaded fitting (Cessna part #S2106-2)
- F) Drain Valve – 1/2 inch 20 thread F391-82 **\$23.60**
For Cessna 206, 207, 210 or aircraft with 1/2 inch 20 threaded fitting (Cessna part #S2020-2)
- G) Drain Valve – 1/8 inch 27 thread F391-187 **\$23.52**
For Piper Arrow or aircraft with 1/8 inch 27 threaded fitting
- H) Drain Valve – 1/8 inch 27 thread F391-187B **\$21.81**
For Piper Arrow or aircraft with 1/8 inch 27 threaded fitting

Flush Fuel Sampler Cup

For use with F391 series flush fuel drain valves. Fuel is only released when you want it to be with the use of our F391 fuel sampler cup, which has a large enough opening to drain fuel into the cup, not all over your arm or in your eyes on a windy day. With the F391 fuel sampler cup, checking your sumps is very simple and can usually be done in less than one minute on the average plane. You can also see water or other contaminants which are flushed from the sump.



Flush Fuel Sampler Cup..... F391-CUP **\$8.08**

Franklin Engine Parts

• All parts below are priced and sold individually

Description	Part #	Price
Propeller Bolt, 8 required for 150/165hp	U17662	\$20.90
Carburetor Gasket, 1 required for 150hp	10942	\$4.83
Crankcase Cover Gasket, 1 required for 150/165hp	RG-18532	\$41.50
Oil Pan Gasket, 1 required for 150/165hp	RG-10366	\$38.25
Magneto Shock Absorber Gear (no. 1 to 32083 engines) 24 required for 150hp, 16 for 165hp.....	10601	\$1.98
Magneto Shock Absorber Gear (no. 32084 and up engines) 2 required for 150/165hp	19313	\$124.58
Valve Lifter Rod Tube Packing (Cylinder End – Small) 24 required for 150hp, 12 for 165hp.....	17864	\$2.34
Valve Lifter Rod Tube Packing (Crankcase End – Large) 12 required for 165hp.....	17794	\$1.44
Crankshaft Oil Seal, 1 required for 150/165hp	17036	\$61.97
Tach Seal	19389	\$19.75

Gaskets Required for Top Overhaul

• Priced and sold individually



Description	Part #	Price
Inlet Manifold Gasket, 6 required for 150/165hp	17671	\$7.48
Valve Cover Gasket, 6 required for 150/165hp	RG-17727	\$9.00
Cylinder Seal Ring, 6 required for 150/165hp.....	17729	\$4.17
Magneto Case, 2 required for 150/165hp.....	5512	\$7.50
Valve Lifter Rod Tube Packing 24 required for 150hp, 12 required for 165hp.....	17864	\$2.34
Valve Lifter Rod Tube Packing (Crankcase End) 12 required for 165hp.....	17794	\$1.44

Shop online at www.univair.com

View our full line of aircraft parts and supplies on our website

Major Overhaul Gasket Set

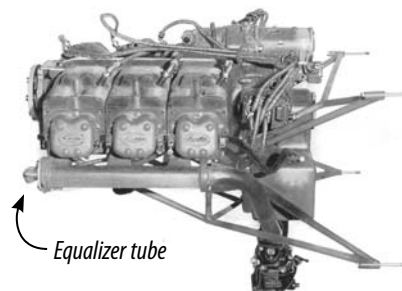

Equalizer tube

Description	Part #	Price
150hp Gasket Set.....	18045	\$759.00
165hp Gasket Set.....	18570	\$759.00

Note: Exhaust gasket not included in kit

Gasket.....	10120	\$17.47
Oil Pan Gasket.....	RG-10366	\$38.25
Gasket.....	18532	\$22.82
Crank Gasket.....	RG-18532	\$41.50

Bushing Kits

• Priced and sold individually

Description	Part #	Price
Crankshaft Bushing, Standard 1 required for 150/165hp	19644	\$436.43
Crankshaft Bushing, .010 Undersize 1 required for 150/165hp	19645	\$419.50
Connecting Rod Bushing, .010 Undersize 12 required for 150/165hp	18020	\$15.26
Connecting Rod Bushing, .020 Undersize 12 required for 150/165hp	18021	\$12.41

Fuel Pumps

Aero Accessories



• FAA/PMA approved direct replacement

Description	Part #	Price
Aero Accessories Fuel Pump – Overhaul	40585	CALL
Aero Accessories Fuel Pump – Overhaul	40695	CALL
Aero Accessories Fuel Pump – Overhaul	631391	CALL
Aero Accessories Fuel Pump – Overhaul (9867)	9051	CALL
Aero Accessories Fuel Pump – Overhaul (4036)	9076	CALL
Aero Accessories Fuel Pump – Overhaul	6861	CALL
Aero Accessories Fuel Pump – New.....	AF-40585	CALL
Aero Accessories Fuel Pump – New.....	AF-40695	\$1,314.09
Aero Accessories Fuel Pump – New.....	AF-631391	CALL
Fuel Pump Gasket	653879	\$3.88

ENGINE • FUEL SYSTEM

Continental Engine	Aero Accessories	TCM	A/C Type
A-65, 8, 8F	AF-40585	40585	9051/9867
C-75, 12, 12F	AF-40695	40695	9076/4036
C-85, 8, 12	AF-40585	40585	9051/9867
C-90, 8, 8F, 12, 12F	AF-40695	40695	9076/4036
C-90, 14F**	**	**	**
C-90, 16F*	AF-631391	631391	6861
O-200*	AF-631391	631391	6861
A-75	AF-40585	40585	9051/9867
A-100	AF-40585	40585	9051/9867
C-125, 2	AF-40585	40585	9051/9867
C-145, 2, 2H	AF-40585	40585	9051/9867

* Uses camshaft part number 626608 or supersedure to which part number 630403 or supersedure Gear and Eccentric has been assembled. Reference Continental Service Bulletin M-76-15.

** See aircraft and engine manual. This engine may use either AC part numbers 9867 or 9076. TCM part numbers 40585 or 40695. Aero Accessories part numbers AF-40585 or AF-40695.

Fuel Tank Accessories

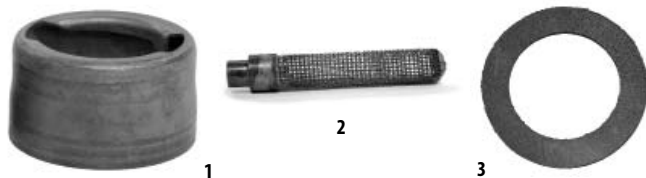

1) Gas Filler Neck and Sleeve..... 415-48033-1 **\$16.05**

These brass filler necks and sleeves are designed to be soldered to a template tank, but can be adapted to almost any tank by soldering a ring to the sleeve and riveting it to your tank.

2) Finger Strainer 415-48081-1 **\$21.67**

To be used in the fuel tank outlet. This little strainer measures 3/8 inch in diameter and 1 1/8 inches long. It has brass end fittings that measure 5/16 inch in outside diameter up to the collar, which has a 7/16 inch outside diameter.

3) Gas Cap Gaskets 13423 **\$3.51**

Leather gas cap gasket measures 2 1/4 inches outside diameter by 1 1/2 inches inside diameter by 3/32 inch thick.

Fuel Valves

Miniature globe valve for use as stop cock or drain cock. Fits 1/8 inch on large end; complete with 3 3/4 inch handle.



Globe Valve FV2002 **\$5.13**

Gascolators

Complete Piper Gascolator

FAA/PMA
APPROVED

- Applicability: Piper J-3, PA-11, PA-12, 14, 15, 16, 17, 18, 20, 22
- Metal bowl with quick drain

Gascolator U14330-002 **\$239.06**



Gascolator for Larger 1/2" Fuel Lines

- 1/2" gascolator with metal bowl and quick drain
- Gascolator for use with 1/2" fuel lines similar to U14330-002 except with large head for 1/2" fuel system

Complete 1/2" Gascolator 1702* **\$328.31**

1/2" Gascolator Head 1700* **\$151.28**

1/2" Gascolator Screen 1701 **\$7.19**

*Requires field approval or STC call out



Gascolator Parts

2 1/8 inch Gasket U85012-032 **\$3.33**

2 inch Gasket LAT-08 **\$3.74**

Gascolator Screen U750-272 **\$2.29**

2 1/8 inch Gascolator Top U87477-002 **\$97.69**

2 1/8 inch Fuel Strainer Bowl U12764-000 **\$108.75**

Gascolator Bail U494-644 **\$55.22**



Gaskets

REAL
GASKET CORP.

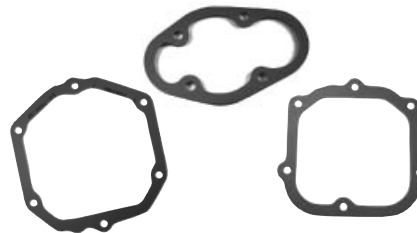

Lycoming	Part #	Price
0-235; 0-290; 0-, IO-, -LIO-320; 0-340; 0-360-A, -B, -C, -D; IO-360-B; HO-360-A, -B; HIO-360-B; VO-, IVO-360; 0-540-A, -B, -E, -F, -G; IO-540-C, -D, -J, -N, -R.....	RG-75906	\$9.00
IO-360-A, -C, -D; AIO-360-A, -B; HO-360-A, -C, -D; TIO-360-A; LIO-360-C1E6; VO-, GO-, TVO-435; GO-480; IO-, VO-, TVIO-540; IO-720	RG-67193	\$9.83
IO-540-B, -E, -M; TIO-540-A; IGO-540-B; IGSO-540-B; TIO-541-A.....	RG-71450	\$11.30

Continental	Part #	Price
A-65; C-75, -85, -90, -145, -175; O-200; O-300	RG-530162	\$8.95
E-185; E-225; IO-346; O-470-A, -E, -J; IO-470-J, -K.....	RG-532451	\$10.40
O-470 except -A, -E, -J; IO-, TSIO-470; IO-, TSIO-520.....	RG-534857	\$11.15
IO-, TIO-, TSIO-360	RG-632310	\$4.65
GTSIO-520; TSIO-520-BE	RG-632459	\$5.05

Franklin	Part #	Price
4A-235; 6A-335; 6A4-150; 6A4-165, -200; 6A-335.....	RG-17727	\$9.00

Lubricant

Avblend Lubricant



- The only FAA approved pure lubricant
- Control damaging rust and corrosion in your engine
- Provide positive lubrication and prevent dry engine starts
- Keep new and rebuilt engines dimensionally correct
- Control critical engine temperatures
- Prevent unnecessary maintenance expense caused by premature wear
- Restore performance to engines with accumulated hours



12 Ounce Can – Single.....	AVBLEND-1	\$19.95
12 Ounce Can – Pack of 4.....	AVBLEND-4	\$74.00

Lycoming Engine Parts

Engine Mount Bushings

- 8 each required
- Priced and sold individually



Bushing Without Collar	60883	\$23.51
Bushing With Collar.....	71032	\$10.78
Bushing Washer	STD-619	\$10.69

Blo-Proof Spiral Wound Gaskets

- These special gaskets are V-shaped spirals wound with layers of stainless steel



For Lycoming engines IO-540; IO-540-B, -E, -M, -WD; IGO-540-B; IGSO-540-B; TIO-540, -541 and TGIO-541	LW15486	\$29.14
For all remaining Lycoming engines	77611	\$9.77

Alternate part numbers 65321 and 75118

Magnetos

Magneto Repair Kits by Aero Accessories



Magneto replacement parts manufactured and sold by Aero Accessories, Inc. are made to specifications dictated by Federal Aviation Administration parts manufacturing approvals. They are highest quality direct replacement parts, approved for installation and use on certified aircraft. Most Aero Accessories, Inc. part numbers include the part number of the original manufacturer ensuring an easy determination of replacement applicability.

Always refer to the parts and service manual of the original equipment manufacturer, or to Aircraft Type Certificate Data Sheets or other FAA approved data to determine eligibility of a part or component for use in any application.

NOTE: The component part kits contain installation hardware.

Bendix Magneto Repair Kit

- For minor repairs such as a 500 hour inspection

AB-485-R	\$292.66
----------------	----------

Includes:

- 1 – Contact Assembly Kit
- 1 – Capacitor
- 2 – Bearings
- 1 – Oil Seal
- 1 – Oil Slinger
- 3 – Woodruff Keys
- 1 – Cotter Pin
- 1 – Cam Screw
- 1 – Felt Washer
- 1 – Felt Strip
- 1 – Snap Ring
- 1 – Carbon Brush



Bendix Magneto Deluxe Repair Kit

- For major repairs such as a magneto overhaul*

AB-485-D	\$728.51
----------------	----------

Includes:

- 1 – Contact Assembly Kit
- 1 – Coil Kit
- 1 – Distributor Block Kit
- 1 – Gear Kit
- 1 – Capacitor
- 2 – Bearings
- 1 – Oil Seal
- 1 – Oil Slinger
- 3 – Woodruff Keys
- 1 – Cotter Pin
- 1 – Cam Screw



* Some parts that need replacing during magneto overhaul are not included in this kit. Refer to the TCM (Bendix) Master Service Manual for additional parts not included in this kit.

Bendix High Tension Terminal Kit

6 Cylinder

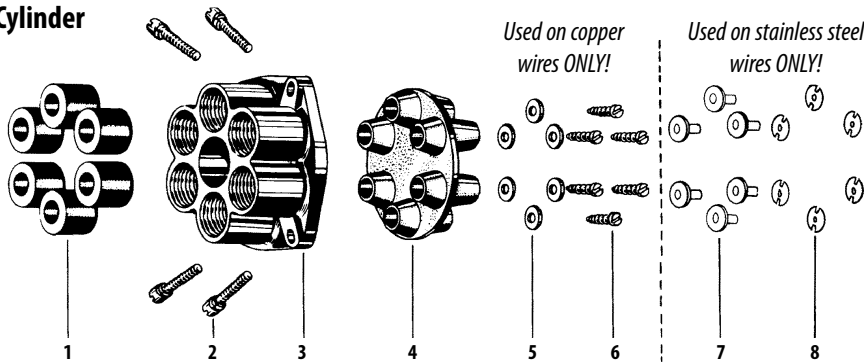

For converting Bendix S6 series magnetos to a shielded system, you will require a High Tension Terminal Kit. The part numbers required will be found in the chart at left. Ground Terminal Kit part numbers may also be found on this chart.

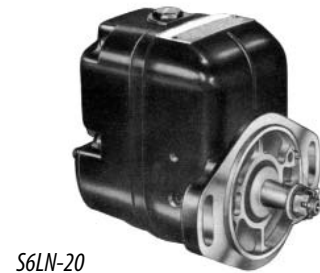

S6LN-20

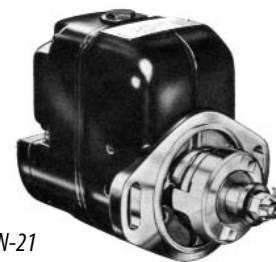

S6LN-21

#	Description	# Req'd	Part #	Price
1)	Grommet (cable protection, used with non-shielding installations).....	6	10-52934	\$5.22
2)	Screw and Lock Washer (cable outlet plate).....	4	10-35937-10	\$1.37
3)	Plate – Cable Outlet (threaded outlets).....	1	10-50766	\$54.16
4)	Grommet – Cable Outlet.....	1	10-50771	\$16.25
5)	Washer – Plain (H.T. cable screw, used only with copper conductor cable).....	6	10-8785	\$0.96
6)	Screw (H.T. cable).....	6	10-14215	\$2.74
7)	Eyelet – H.T. Cable Contact (used only with stainless steel conductor cable)....	6	10-163012	\$2.82
8)	Washer (alternate method of securing stainless steel wires).....	6	10-51677	\$7.06

H.T. = High Tension

Components for Complete Magneto Installation

Each magneto requires a high tension terminal kit and a ground terminal kit.

Type	Mag Ref #	Replaces Part #	High Tension Terminal Kit		Ground Terminal Kit	
			Part #	Price	Part #	Price
S6LN-20	10-51365-31	10-51365-15	10-52936	\$168.27	10-52305-1	\$88.66
S6LN-20	10-51360-33	10-51365-25				
S6LN-20	10-51365-43	10-51365-17				
S6LN-20	10-51365-44	10-51365-29				
S6LN-20	10-51365-46	10-51365-27				
S6LN-21	10-51365-32	10-51365-20	10-52936	\$168.27	10-52305-1	\$88.66
S6LN-21	10-51365-39	10-51365-1				
S6LN-21	10-51365-42	10-51365-16				
S6LN-21	10-51365-45	10-51365-30				
S6LN-21	10-51365-47	10-51365-28				
S6RN-21	10-51365-34	10-51365-26	10-52936	\$168.27	10-52305-1	\$88.66
S6RN-21	10-51365-35	—				
S6RN-21	10-51365-40	10-51365-2, -13				
S6RN-21	10-51365-48	10-51365-7, -14				
S6RN-21	10-51365-41	10-51365-5	10-52936	\$168.27	10-52306	\$77.73
S6LN-22	10-52350-22	10-52350-14, -17	10-52936	\$168.27	10-52306	\$77.73
S6LN-23	10-52350-20	10-52350-6	10-52936	\$168.27	10-52306	\$77.73
S6RN-23	10-52350-19	10-52350-2	10-52936	\$168.27	10-52306	\$77.73
S6RN-23	10-52350-21	10-52350-8				
S6RN-23	10-52350-23	10-52350-15,-18				
S6RN-25	10-79020-8	10-79020-2, -5	10-52936	\$168.27	10-52305-1	\$88.66
S6RN-26	10-85290-2	Not Changed	10-52936	\$168.27	10-52305-1	\$88.66

Inductor Magneto Synchronizers



Model AA002 shown

Space Age Electronics

This INDUCTOR Magneto Timing Device is a new concept utilizing the latest digital integrated circuitry, thus eliminating the need for the battery draining mechanical buzzer found in most of the older magneto timing lights. The timing indicators are light emitting diodes (LEDs) rather than the commonly used incandescent bulbs, further extending battery life. Since the device measures change of inductance in the magneto coil, it will not give a false reading should the clip leads pop off or become shorted. The INDUCTOR can also be used as a relay coil tester to determine whether the coil is functioning.

Size

One of the INDUCTOR's most convenient features is its compact size. It measures ¾ by 3 by 5 inches and is packaged in an anodized aluminum case that will neither melt nor break. It fits into the mechanic's tool box or shirt pocket and weighs only nine ounces.

Power

The INDUCTOR is powered by a 9-volt Duracell® battery. With the inherent low power drain of the device and prudent use of the on-off switch, the battery should function for as long as its shelf life. If the LEDs fail to toggle when the magneto points open or close, it is an indication that the battery needs changing.

Single Magneto Synchronizer Model.....AA001	\$51.88
Dual Magneto Synchronizer Model.....AA002	\$47.50
Single Magneto Synchronizer with Tweeter*	\$48.95
Dual Magneto Synchronizer with Tweeter*	\$55.95

* Models with a tweeter provide audio as well as visual indication of operation.

Manuals

Eisemann Manual

The Eisemann magnetos manual contains service and overhaul information, exploded views and parts listings.

Eisemann LA Series Magnetos Handbook and Instructions.....E-LAHB	\$16.14
--	----------------



Continental Engine Manuals

Continental Owners Manuals

A and C Series, 4-cylinder, Owners Manual..... AC4WM	\$9.68
A and C Series, 6-cylinder, Owners Manual..... AC6WM	\$9.68
C Series, 6-cylinder, Owners Manual.....C6WM	\$9.68
O Series, 6-cylinder, Owners Manual.....CO6WM	\$9.68

C-65/75/90/200 Operators Manual.....X30012	\$37.50
C-125/C-145/O-300 Operators Manual.....X30015	\$28.94
G0-300 Operators Manual.....X30021	\$38.25
IO-470-C Operators Manual.....X30024	\$51.42
IO-520 Operators Manual.....X30041	\$36.72
O-470 Operators Manual.....X30097	\$36.72
IO-550D, E, F, L Maintenance and Operators Manual.....X30605	\$51.42
IO-360 Series Maintenance and Operators Manual.....X30617	\$35.00

Continental Parts Manuals

"C" Series Parts Manual (C-75, C-85, C-90, O-200).....X30011A	\$40.50
IO-520 Parts Manual (B, BA, BB, C, CB, M, MB).....X30624A	\$55.00
IO-360 Parts Manual.....X30595A	\$60.00
TSIO-520 Sandcast Series Parts Catalog.....X30579A	\$60.00

Continental Service and Overhaul Manuals

A-65, A-75 Parts and Overhaul Manual.....X30008	\$83.94
W670 Overhaul Manual.....X30009	\$111.89
"C" Series Maintenance and Overhaul Manual (C-75, C-85, C-90, O-200).....X30010A	\$83.94
C-125, C-145, O-300 Overhaul Manual.....X30013	\$83.94
E165/185/225 Overhaul Manual.....X30016	\$83.94
G0-300 Overhaul Manual.....X30019	\$80.00
IO-520 Overhaul Manual.....X30039A	\$80.00
O-470 Overhaul Manual.....X30586A	\$111.89
IO-470 Overhaul Manual.....X30588A	\$111.89
IO-360 Overhaul Manual.....X30594A	\$80.00
TSIO-360 Overhaul Manual.....X30596A	\$75.00

Franklin Engine Manuals

Service Parts List, 6A4-150-B3 and 6A4-145-A3 (Not Illustrated).....F150PM	\$16.85
Service Parts List, 6A4-165-B3/B31 (Not Illustrated).....F165PM	\$16.85
Service Manual, 6A4-150-B3/B31 and 6A4-165-B3.....FESM	\$21.52
Service Bulletins and Letters.....FESB	\$45.90

Lycoming Engine Manuals

Lycoming Operators Manuals

O-235-C, O-290-D/D2 Series.....60297-9	\$42.00
O-320, IO-320, AIO-320 and LIO-320 Series.....60297-16	\$23.11
O-360 "76" Series.....60297-25	\$42.00
O-320 Series.....60297-30	\$45.00

Lycoming Parts Manuals

O-145 and G0-145 Instructions and Parts Manual and Magneto Section.....L145PM	\$18.29
O-290-D Series.....PC102-1	\$63.00
Model O-340.....PC105	\$52.50
O-320-A and O-320-E.....PC203-1	\$63.00
O-320-B and O-320-D.....PC203-2	\$63.00
O-235.....PC302	\$63.00
O-360-A.....PC306-1	\$63.00

Oil Filters

Aircraft Model	Engine Model	Spin-On Filter	Element
■ AERO COMMANDER AIRCRAFT – SINGLE ENGINE			
100, Darter	O-320	CH48110-1	CF0100-1
112	IO-360	CH48103-1	CF0100-1
AG, A-9 Sparrow	O-540	CH48110-1	CF0100-1
■ BEECH SINGLE ENGINE MODELS			
<i>Bonanza</i>			
E33A, F33A, F33C	IO-520	CH48109-1	CF0100-1
S35, V35, V35A, V35B	IO-520	CH48109-1	CF0100-1
V35TC, V35A-TC, V35B-TC	TSIO-520	CH48109-1	CF0100-1
<i>Debonair</i>			
C33A, E33A, E33C	IO-520	CH48109-1	CF0100-1
<i>Muskeeter</i>			
		<i>with Stud</i>	<i>w/o Stud</i>
Sport III	O-320	CH48110-1	CH48103-1
23	O-320	CH48110-1	CH48103-1
A23-19, 19A, B19	O-320	CH48110-1	CH48103-1
A23, 23, A23A	IO-346	CH48110-1	CH48103-1
B23, C23	O-360	CH48110-1	CH48103-1
■ CESSNA SINGLE ENGINE MODELS			
150	O-200	CH48110-1	CH48103-1
F150	O-200	CH48110-1	CH48103-1
A150	O-200	CH48110-1	CH48103-1
FA150	O-200	CH48110-1	CH48103-1
172	O-300	CH48110-1	CH48103-1
172	O-320	CH48110-1	CH48103-1
F172	O-300	CH48110-1	CH48103-1
177	O-320	CH48110-1	CH48103-1
FR172	IO-360	CH48110-1	CH48103-1
180	O-470	CH48110-1	CH48103-1
182	O-470	CH48110-1	CH48103-1
A182	O-470	CH48110-1	CH48103-1
185	IO-470, IO-520	CH48110-1	CH48103-1
A185	IO-470, IO-520	CH48110-1	CH48103-1

Aircraft Model	Engine Model	Spin-On Filter	Element
188	O-470, O-520	CH48110-1	CH48103-1
205	IO-470	CH48110-1	CH48103-1
206	IO-520	CH48110-1	CH48103-1
U206	IO-520	CH48110-1	CH48103-1
TU206	TSIO-520	CH48110-1	CH48103-1
P206	IO-520	CH48110-1	CH48103-1
TP206	TSIO-520	CH48110-1	CH48103-1
207	IO-520	CH48110-1	CH48103-1
T207	TSIO-520	CH48110-1	CH48103-1
210	IO-470, IO-520	CH48110-1	CH48103-1
T210	TSIO-520	CH48110-1	CH48103-1
■ MOONEY AIRCRAFT			
M20	O-320	CH48110-1	CH48103-1
M20A, M20B, Mark 21, M20D Master	O-360	CH48110-1	CH48103-1
201 Chaparral	IO-360	CH48110-1	CH48103-1
222 Mark	TIO-541	CH48110-1	CH48103-1
■ PIPER SINGLE ENGINE MODELS			
<i>Tri-Pacer</i>			
PA-22 "150"	O-320	CH48110-1	CH48103-1
PA-22 "160"	O-320	CH48110-1	CH48103-1
<i>Comanche</i>			
PA-24 "180"	O-360	CH48110-1	CH48103-1
PA-24 "250"	O-540, IO-540	CH48110-1	CH48103-1
PA-24B, PA-24C "260"	O-540	CH48110-1	CH48103-1
PA-24B, PA-24C "260"	IO-540	CH48110-1	CH48103-1
PA-24 Turbo "260"	IO-540	CH48110-1	CH48103-1
<i>Pawnee</i>			
PA-25 "150"	O-320	CH48110-1	CH48103-1
PA-25 "260"	O-540	CH48110-1	CH48103-1
<i>Cherokee</i>			
PA-28 "140"	O-320	CH48110-1	CH48103-1
PA-28 "150"	O-320	CH48110-1	CH48103-1
PA-28 "160"	O-320	CH48110-1	CH48103-1
PA-28 "180"	O-360	CH48110-1	CH48103-1
PA-28 "235"	O-540	CH48110-1	CH48103-1

Aircraft Model	Engine Model	Spin-On Filter	Element
Arrow			
PA-28R "180"	IO-360	CH48110-1	CH48103-1 CF0100-1
PA-28R "200"	IO-360	CH48110-1	CH48103-1 CF0100-1
Cherokee Six			
PA-32 "260"	O-540	CH48110-1	CH48103-1 CF0100-1
PA-32 "300"	IO-540	CH48110-1	CH48103-1 CF0100-1

Oil Filter Prices

Champion Oil Filter Assembly	CH48103-1	\$29.18
Champion Oil Filter Assembly	CH48109-1	\$31.95
Champion Oil Filter Assembly	CH48110-1	\$30.07
Champion Oil Filter Element	CF0100-1	\$27.98

Contact Univair for availability of the oil filter assembly and engine adapter

Shielded Ignition Leads

1. Select the Correct Ignition Lead Model

To order the correct lead, select the ignition lead model from the table on the right based on your magneto type.

Example: An engine with 5/8 x 24 spark plugs and a Scintilla S6 series magneto with threaded cap uses a 101 model lead.

NOTE: Threaded high tension terminal plates must be used when upgrading from unshielded to shielded ignition leads. See page 178 for Bendix Magneto details.

2. Find the Right Lead Length

If you are replacing an existing lead, measure the exact length, **ferrule-to-ferrule**, and use this as the last part of your order number. Leads are manufactured in 3" increments from 19" to 60".

Example: If you need a 101 series lead and the ferrule-to-ferrule measurement is 33 inches long, the Univair part number would be 101-33.

Spark Plug Selection	
Magneto Selection	5/8 x 24
Eisemann LA-4	Use model 102
Eisemann LA-6	Use model 102
Scintilla SF-4 Series	Use model 104
Scintilla SF-6 Series	Use model 104
Scintilla S4 Series with Threaded Cap	Use model 101
Scintilla S6 Series with Threaded Cap	Use model 101

Model 101



5/8 x 24 plugs and Bendix Scintilla S4, S6 series with threaded cap, and Bendix S20, S200, S700, S1200 and D2000 magnetos with threaded 11/64 x 24 male outlets.

Elbow Design	5/8 x 24, 70°
Terminal Design – Spark Plug End	Standard glazed ceramic 9/16 insulator, silicone rubber grommet
Terminal Design – Magneto End	11/16 x 24 male thread square head nut
Wire Size and Type	7 mm shielded
Availability (in 3" increments)	101-15 through 101-72

Model 102

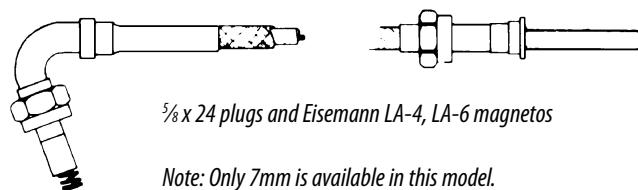

5/8 x 24 plugs and Eisemann LA-4, LA-6 magnetos

Note: Only 7mm is available in this model.

Elbow Design	5/8 x 24, 70°
Terminal Design – Spark Plug End	Standard glazed ceramic 9/16 insulator, silicone rubber grommet
Terminal Design – Magneto End	11/16 x 24 female thread hex head nut
Wire Size and Type	7 mm shielded
Availability (in 3" increments)	102-21 through 102-69

Model 104

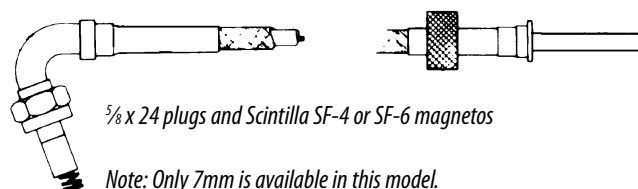

5/8 x 24 plugs and Scintilla SF-4 or SF-6 magnetos

Note: Only 7mm is available in this model.

Elbow Design	5/8 x 24, 70°
Terminal Design – Spark Plug End	Standard glazed ceramic 9/16 insulator, silicone rubber grommet
Terminal Design – Magneto End	3/4 x 18 female thread knurled round nut
Wire Size and Type	7 mm shielded
Availability (in 3" increments)	104-21 through 104-54 104-60 through 104-69

Routing Charts

To determine your requirement:

- Check your spark plug
- Check your magneto
- Check the chart under your engine

All the information to assist you in determining your need is given in the charts below and the preceding page.

The length of the lead is shown in the chart under your specific engine. Length is measured **ferrule-to-ferrule**, with length designated after the dash in the part number. *Example: Part number 101-42 is a 42 inch lead.* Make selection of as many leads as your engine requires.

Price chart on page 185

Continental Engines

Engine Model A50, A65, A75, A80

Bendix S4RN-20, S4RN-21 • Plug Nut 5/8 x 24

Cylinder	Magneto	101 Lead	102 Lead	104 Lead
T1	1R	101-24	102-24	104-24
T2	3L	101-36	102-36	104-36
T3	2R	101-30	102-30	104-30
T4	4L	101-33	102-33	104-33
B1	1L	101-36	102-36	104-36
B2	3R	101-24	102-24	104-24
B3	2L	101-27	102-27	104-27
B4	4R	101-33	102-33	104-33
Lead Set		101-105	102-105	104-105

Engine Model CF75-12, -12F, -12FJ, C85-12F, -12FJ, C90-12, 0200A

Bendix S4LN-21 • Plug Nut 5/8 x 24

Cylinder	Magneto	101 Lead	102 Lead	104 Lead
T1	1R	101-39	102-39	104-39
T2	3R	101-42	102-42	104-42
T3	2R	101-42	102-42	104-42
T4	4R	101-42	102-42	104-42
B1	1L	101-39	102-39	104-39
B2	3L	101-39	102-39	104-39
B3	2L	101-42	102-42	104-42
B4	4L	101-42	102-42	104-42
Lead Set		101-106	102-106	104-106

Engine Model C85-8, -8F, C90-8F, -8FJ

Bendix S4LN-21 • Plug Nut 5/8 x 24

Cylinder	Magneto	101 Lead	102 Lead	104 Lead
T1	1R	101-39	102-39	104-39
T2	3R	101-42	102-42	104-42
T3	2R	101-42	102-42	104-42
T4	4R	101-42	102-42	104-42
B1	1L	101-36	102-36	104-36
B2	3L	101-36	102-36	104-36
B3	2L	101-42	102-42	104-42
B4	4L	101-39	102-39	104-39
Lead Set		101-107	102-107	104-107

Engine Model C125, C145, 0300

Bendix S6LN-21 • Plug Nut 5/8 x 24

Cylinder	Magneto	101 Lead	102 Lead	104 Lead
T1	1R	101-33	102-33	104-33
T2	4R	101-36	102-36	104-36
T3	3R	101-42	102-42	104-42
T4	6R	101-48	102-48	104-48
T5	5R	101-42	102-42	104-42
T6	2R	101-48	102-48	104-48
B1	1L	101-39	102-39	104-39
B2	4L	101-36	102-36	104-36
B3	3L	101-45	102-45	104-45
B4	6L	101-42	102-42	104-42
B5	5L	101-51	102-51	104-51
B6	2L	101-48	102-48	104-48
Lead Set		101-108	102-108	104-108

Engine Model G0-300A

Bendix S6RN-21 • Plug Nut 5/8 x 24

Cylinder	Magneto	101 Lead	102 Lead	104 Lead
T1	1R	101-36	102-36	104-36
T2	4R	101-39	102-39	104-39
T3	5R	101-39	102-39	104-39
T4	2R	101-51	102-51	104-51
T5	3R	101-45	102-45	104-45
T6	6R	101-54	102-54	104-54
B1	1L	101-36	102-36	104-36
B2	4L	101-33	102-33	104-33
B3	5L	101-48	102-48	104-48
B4	2L	101-42	102-42	104-42
B5	3L	101-51	102-51	104-51
B6	6L	101-48	102-48	104-48
Lead Set		101-109	102-109	104-109

Engine Model E165, E185, E225

Bendix S6LN-21 • Plug Nut 5/8 x 24

Cylinder	Magneto	101 Lead	102 Lead	104 Lead
T1	1R	101-36	102-36	104-36
T2	4R	101-42	102-42	104-42
T3	3R	101-45	102-45	104-45
T4	6R	101-51	102-51	104-51
T5	5R	101-48	102-48	104-48
T6	2R	101-48	102-48	104-48
B1	1L	101-36	102-36	104-36
B2	4L	101-33	102-33	104-33
B3	3L	101-45	102-45	104-45
B4	6L	101-45	102-45	104-45
B5	5L	101-51	102-51	104-51
B6	2L	101-45	102-45	104-45
Lead Set		101-110	102-110	104-110

Chart Symbol Definitions

Cylinder column: T = Top, B = Bottom

Magneto column: L = Left, R = Right

Prices on page 185

Engine Model E165, E185, E225 Crossfire

Bendix S6LN-21 • Plug Nut 5/8 x 24

Cylinder	Magneto	101 Lead	102 Lead	104 Lead
T1	1R	101-33	102-33	104-33
T2	4L	101-42	102-42	104-42
T3	3R	101-42	102-42	104-42
T4	6L	101-45	102-45	104-45
T5	5R	101-48	102-48	104-48
T6	2L	101-48	102-48	104-48
B1	1L	101-33	102-33	104-33
B2	4R	101-36	102-36	104-36
B3	3L	101-42	102-42	104-42
B4	6R	101-48	102-48	104-48
B5	5L	101-48	102-48	104-48
B6	2R	101-48	102-48	104-48
Lead Set		101-111	102-111	104-111

Engine Model 0470-4, -11, -13A

Bendix S6LN-21 • Plug Nut 5/8 x 24

Cylinder	Magneto	101 Lead	102 Lead	104 Lead
T1	1R	101-33	102-33	104-33
T2	4L	101-39	102-39	104-39
T3	3R	101-42	102-42	104-42
T4	6L	101-45	102-45	104-45
T5	5R	101-48	102-48	104-48
T6	2L	101-51	102-51	104-51
B1	1L	101-42	102-42	104-42
B2	4R	101-42	102-42	104-42
B3	3L	101-48	102-48	104-48
B4	6R	101-51	102-51	104-51
B5	5L	101-54	102-54	104-54
B6	2R	101-54	102-54	104-54
Lead Set		101-112	102-112	104-112

Engine Model 0470B, -J, -K, -L, -M, -R, etc., IO-470 Series, IO-520 Series

Bendix S6RN-25 • Plug Nut 5/8 x 24

Cylinder	Magneto	101 Lead	102 Lead	104 Lead
T1	1R	101-18	102-18	104-18
T2	4L	101-18	102-18	104-18
T3	3R	101-18	102-18	104-18
T4	6L	101-18	102-18	104-18
T5	5R	101-21	102-21	104-21
T6	2L	101-21	102-21	104-21
B1	1L	101-36	102-36	104-36
B2	4R	101-36	102-36	104-36
B3	3L	101-36	102-36	104-36
B4	6R	101-33	102-33	104-33
B5	5L	101-39	102-39	104-39
B6	2R	101-39	102-39	104-39
Lead Set		101-113	102-113	104-113

Lycoming Engines

Engine Model O-235, O-290

Bendix S4LN-20, S4LN-21 • Plug Nut 5/8 x 24

Cylinder	Magneto	101 Lead	102 Lead	104 Lead
T1	1R	101-33	102-33	104-33
T2	3L	101-33	102-33	104-33
T3	2R	101-27	102-27	104-27
T4	4L	101-27	102-27	104-27
B1	1L	101-51	102-51	104-51
B2	3R	101-48	102-48	104-48
B3	2L	101-45	102-45	104-45
B4	4R	101-42	102-42	104-42
Lead Set		101-114	102-114	104-114

Engine Model O-320, O-340-A1A

Bendix S4LN-21 • Plug Nut 5/8 x 24

Cylinder	Magneto	101 Lead	102 Lead	104 Lead
T1	1R	101-33	102-33	104-33
T2	3L	101-33	102-33	104-33
T3	2R	101-27	102-27	104-27
T4	4L	101-24	102-24	104-24
B1	1L	101-51	102-51	104-51
B2	3R	101-48	102-48	104-48
B3	2L	101-45	102-45	104-45
B4	4R	101-42	102-42	104-42
Lead Set		101-115	102-115	104-115

Engine Model O-320A, -B, O-360

Bendix S4LN-20, S4LN-21 • Plug Nut 5/8 x 24

Cylinder	Magneto	101 Lead	102 Lead	104 Lead
T1	1R	101-36	102-36	104-36
T2	3L	101-36	102-36	104-36
T3	2R	101-30	102-30	104-30
T4	4L	101-30	102-30	104-30
B1	1L	101-54	102-54	104-54
B2	3R	101-51	102-51	104-51
B3	2L	101-48	102-48	104-48
B4	4R	101-45	102-45	104-45
Lead Set		101-116	102-116	104-116

Engine Model O-435A

Bendix S6LN-50, S6LN-51 • Plug Nut 5/8 x 24

Cylinder	Magneto	101 Lead	102 Lead	104 Lead
T1	1R	101-33	102-33	104-33
T2	3L	101-33	102-33	104-33
T3	2R	101-27	102-27	104-27
T4	4L	101-27	102-27	104-27
T5	4L	101-21	102-21	104-21
T6	4L	101-21	102-21	104-21
B1	1L	101-51	102-51	104-51
B2	3R	101-54	102-54	104-54
B3	2L	101-48	102-48	104-48
B4	4R	101-51	102-51	104-51
B5	4R	101-45	102-45	104-45
B6	4R	101-48	102-48	104-48
Lead Set		101-117	102-117	104-117

Chart Symbol Definitions

Cylinder column: T = Top, B = Bottom
 Magneto column: L = Left, R = Right

Prices on page 185

Engine Model O-435-23

Bendix S6LN-20, S6RN-21 • Plug Nut 5/8 x 24

Cylinder	Magneto	101 Lead	102 Lead	104 Lead
T1	1R	101-27	102-27	104-27
T2	4L	101-27	102-27	104-27
T3	5R	101-21	102-21	104-21
T4	2L	101-18	102-18	104-18
T5	3R	101-15	102-15	104-15
T6	6L	101-21	102-21	104-21
B1	1L	101-60	102-60	104-60
B2	4R	101-63	102-63	104-63
B3	5L	101-57	102-57	104-57
B4	2R	101-60	102-60	104-60
B5	3L	101-60	102-60	104-60
B6	6R	101-51	102-51	104-51
Lead Set		101-118	102-118	104-118

Engine Model O-540

Bendix S6LN-20, S6RN-21 • Plug Nut 5/8 x 24

Cylinder	Magneto	101 Lead	102 Lead	104 Lead
T1	1R	101-45	102-45	104-45
T2	4L	101-45	102-45	104-45
T3	5R	101-39	102-39	104-39
T4	2L	101-39	102-39	104-39
T5	3R	101-36	102-36	104-36
T6	6L	101-30	102-30	104-30
B1	1L	101-54	102-54	104-54
B2	4R	101-54	102-54	104-54
B3	5L	101-48	102-48	104-48
B4	2R	101-45	102-45	104-45
B5	3L	101-42	102-42	104-42
B6	6R	101-42	102-42	104-42
Lead Set		101-119	102-119	104-119

Engine Model GO-480-C2D6, GO-480-C2

Bendix S6LN-20, S6LN-21 • Plug Nut 5/8 x 24

Cylinder	Magneto	101 Lead	102 Lead	104 Lead
T1	1R	101-45	102-45	104-45
T2	4L	101-42	102-42	104-42
T3	5R	101-36	102-36	104-36
T4	2L	101-36	102-36	104-36
T5	3R	101-27	102-27	104-27
T6	6L	101-30	102-30	104-30
B1	1L	101-69	102-69	104-69
B2	4R	101-72	102-72	104-72
B3	5L	101-63	102-63	104-63
B4	2R	101-66	102-66	104-66
B5	3L	101-54	102-54	104-54
B6	6R	101-63	102-63	104-63
Lead Set		101-120	102-120	104-120

Engine Model GSO-480-A1A-6

Bendix S6LN-20, S6LN-21 • Plug Nut 5/8 x 24

Cylinder	Magneto	101 Lead	102 Lead	104 Lead
T1	1R	101-33	102-33	104-33
T2	4L	101-30	102-30	104-30
T3	5R	101-27	102-27	104-27
T4	2L	101-24	102-24	104-24
T5	3R	101-24	102-24	104-24
T6	6L	101-21	102-21	104-21
B1	1L	101-63	102-63	104-63
B2	4R	101-57	102-57	104-57
B3	5L	101-57	102-57	104-57
B4	2R	101-57	102-57	104-57
B5	3L	101-60	102-60	104-60
B6	6R	101-57	102-57	104-57
Lead Set		101-121	102-121	104-121

**Engine Model VO-435-A1B, -A1C, -A1D,
GO-480-C1B, -C1B6, GSO-480-A1A, -A1A6**

Bendix S6LN-20, S6RN-21 • Plug Nut 5/8 x 24

Cylinder	Magneto	101 Lead	102 Lead	104 Lead
T1	1R	101-33	102-33	104-33
T2	4L	101-30	102-30	104-30
T3	5R	101-24	102-24	104-24
T4	2L	101-21	102-21	104-21
T5	3R	101-21	102-21	104-21
T6	6L	101-15	102-15	104-15
B1	1L	101-66	102-66	104-66
B2	4R	101-66	102-66	104-66
B3	5L	101-57	102-57	104-57
B4	2R	101-63	102-63	104-63
B5	3L	101-57	102-57	104-57
B6	6R	101-57	102-57	104-57
Lead Set		101-122	102-122	104-122

Engine Model GO-435-C2, -C2B, GO-480-F6

Bendix S6LN-50, S6LN-51 • Plug Nut 5/8 x 24

Cylinder	Magneto	101 Lead	102 Lead	104 Lead
T1	1R	101-36	102-36	104-36
T2	4L	101-36	102-36	104-36
T3	5R	101-30	102-30	104-30
T4	2L	101-30	102-30	104-30
T5	3R	101-24	102-24	104-24
T6	6L	101-27	102-27	104-27
B1	1L	101-66	102-66	104-66
B2	4R	101-69	102-69	104-69
B3	5L	101-63	102-63	104-63
B4	2R	101-66	102-66	104-66
B5	3L	101-60	102-60	104-60
B6	6R	101-66	102-66	104-66
Lead Set		101-123	102-123	104-123

Toll Free Sales: 1-888-433-5433

Monday-Friday 7:30 a.m. – 5:00 p.m. MT

Order online at www.univair.com

Franklin Engines

Engine Model 6A4-150-B3, -B31

Bendix S6RN-21 • Plug Nut 5/8 x 24

Cylinder	Magneto	101 Lead	102 Lead	104 Lead
T1	1R	101-42	102-42	104-42
T2	4L	101-45	102-45	104-45
T3	5R	101-45	102-45	104-45
T4	2L	101-51	102-51	104-51
T5	3R	101-48	102-48	104-48
T6	6L	101-54	102-54	104-54
B1	1L	101-36	102-36	104-36
B2	4R	101-30	102-30	104-30
B3	5L	101-45	102-45	104-45
B4	2R	101-42	102-42	104-42
B5	3L	101-51	102-51	104-51
B6	6R	101-45	102-45	104-45
Lead Set		101-124	102-124	104-124

Engine Model 6A4-165-B3

Bendix S6RN-21 • Plug Nut 5/8 x 24

Cylinder	Magneto	101 Lead	102 Lead	104 Lead
T1	1R	101-36	102-36	104-36
T2	4L	101-39	102-39	104-39
T3	5R	101-39	102-39	104-39
T4	2L	101-48	102-48	104-48
T5	3R	101-42	102-42	104-42
T6	6L	101-48	102-48	104-48
B1	1L	101-30	102-30	104-30
B2	4R	101-24	102-24	104-24
B3	5L	101-42	102-42	104-42
B4	2R	101-36	102-36	104-36
B5	3L	101-45	102-45	104-45
B6	6R	101-39	102-39	104-39
Lead Set		101-125	102-125	104-125

Prices for Shielded Ignition Leads

101-15	\$49.82
101-18	\$49.82
101-21	\$49.82
101-24	\$69.03
101-27	\$71.26
101-30	\$67.62
101-33	\$55.78
101-36	\$57.18
101-39	\$54.69
101-42	\$75.28
101-45	\$74.38
101-48	\$74.38
101-51	\$75.68
101-54	\$78.32
101-57	\$49.82
101-60	\$53.36
101-61	\$53.36
101-63	\$53.36
101-69	\$53.36
101-72	\$68.60
101-105	\$380.80
101-106	\$380.80
101-107	\$424.90
101-108	\$542.52
101-109	\$566.04
101-110	\$566.04
101-111	\$566.04
101-112	\$566.04
101-113	\$566.04
101-114	\$380.80
101-115	\$380.80

101-116	\$380.80
101-117	\$566.04
101-118	\$566.04
101-119	\$566.04
101-120	\$527.82
101-121	\$419.02
101-122	\$477.83
101-123	\$424.90
101-124	\$566.04
101-125	\$566.04
102-15	\$62.88
102-18	\$75.85
102-21	\$61.26
102-24	\$56.25
102-27	\$58.01
102-30	\$50.63
102-33	\$50.63
102-36	\$68.25
102-39	\$73.45
102-42	\$76.62
102-45	\$50.63
102-48	\$50.63
102-51	\$50.63
102-54	\$50.63
102-57	\$50.63
102-60	\$50.63
102-63	\$50.63
102-65	\$50.63
102-66	\$50.63
102-69	\$51.81
102-72	\$50.63

102-105	\$380.80
102-106	\$380.80
102-107	\$380.80
102-108	\$586.63
102-109	\$586.63
102-110	\$586.63
102-111	\$586.63
102-112	\$586.63
102-113	\$586.63
102-114	\$380.80
102-115	\$380.80
102-116	\$380.80
102-117	\$586.63
102-118	\$586.63
102-119	\$586.63
102-120	\$586.63
102-121	\$586.63
102-122	\$586.63
102-123	\$586.63
102-124	\$586.63
102-125	\$586.63
104-14	\$49.82
104-15	\$49.82
104-18	\$49.82
104-19	\$49.82
104-21	\$64.45
104-22	\$49.82
104-24	\$74.82
104-25	\$64.45
104-27	\$76.00
104-28	\$64.45
104-30	\$69.50
104-33	\$77.96
104-36	\$83.96

104-39	\$55.09
104-42	\$61.42
104-45	\$49.82
104-48	\$49.82
104-51	\$49.82
104-54	\$53.50
104-57	\$49.82
104-60	\$49.82
104-63	\$51.81
104-66	\$49.82
104-69	\$49.82
104-72	\$49.82
104-105	\$380.80
104-106	\$380.80
104-107	\$380.80
104-108	\$566.04
104-109	\$566.04
104-110	\$566.04
104-111	\$566.04
104-112	\$514.58
104-113	\$514.58
104-114	\$380.80
104-115	\$380.80
104-116	\$350.52
104-117	\$566.04
104-118	\$566.04
104-119	\$566.04
104-120	\$586.63
104-121	\$566.04
104-122	\$566.04
104-123	\$527.82
104-124	\$566.04
104-125	\$566.04

Spark Plugs

Champion REM37BY 18mm "Short" Spark Plug

To be used with shielded ignition leads. The shorter length provides for adequate cowl clearance. This eliminates the need to modify cowling in many applications.

Champion Spark Plug.....REM37BY **\$41.93**



Inside a Champion Spark Plug

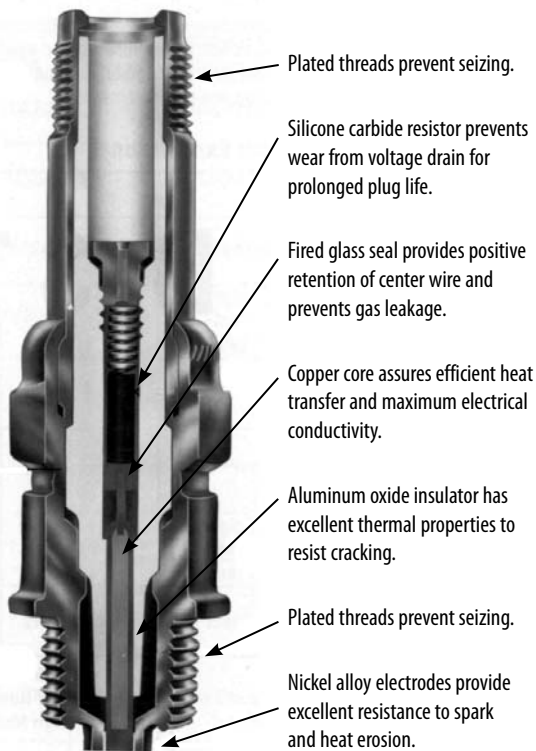

Advanced-engineered Champion aviation spark plugs are designed for the critical difference in performance, far beyond the ordinary. Champion aviation spark plugs stand up to high temperatures, pressures and lead deposits, with a performance second to none. When you're up in the air, count on quality Champion spark plugs.

The #1 Choice Worldwide – OEM for all U.S. Piston Engines
Champion spark plugs are a product of Champion Spark Plug Company's commitment to quality and advanced technology, a commitment that has made Champion spark plugs the #1 choice of engine manufacturers, maintenance technicians and pilots around the world.

General Spark Plug Cross Reference

A/C / Auburn	Champion	Price
14mm		
SA43*	REJ38	\$63.00
A44**	J43*	N/A
SR47P*	REL37W*	N/A

18mm Fine Wire (Long Reach)

181*	REB36W*, REB36P*	N/A
281*	RHB36S	\$120.00
291*	RHB36W	\$63.76
283*	RHB32*	N/A
293*	RHB32W*	N/A
286*	N/A	N/A

18mm Fine Wire (Short Reach)

SR83P*	REM38S	\$135.68
HSR83P*	RHM38P*	N/A
SR93*	REM38S	\$135.68
HSR93*	RHM38S	\$120.00

18mm Massive Electrode (Short Reach)

A88*	M41E, M42E	\$49.80
S88*	EM42E*	N/A
HS88*	RHM40E	\$41.33
SR88*	REM40E	\$38.93
HSR88*	RHM40E	\$41.33
SR87*	REM38E	\$37.73
HSR87*	RHM38E	\$41.33
SR86*	REM38E	\$37.73
HSR86*	RHM38E	\$41.33

18mm Massive Electrode (Long Reach)

171*	REB37E*, REB37N*	N/A
271*	RHB37N*, RHB38E*, RHB37E	\$37.73
172*	REB87N*	N/A
273*	RHB32N*, RHB33E*, RHB32E	\$38.93
175*	REB29N*	N/A
275*	RHB29N*, RHB29E*	N/A

* Plug is no longer available from Univair

**A44 plug is unshielded and has no resistor

Miscellaneous Spark Plugs



While supplies last!

A/C	LS87	\$13.98
A/C	LS86	\$13.98
Champion (Fine Wire)	RHB36S	\$120.00
Champion	REA37N	\$8.41
BG	BG417	\$13.98

Auburn and Champion Spark Plug Cross Reference

- Massive electrode
- Shielded unless otherwise noted
- U.S. aircraft and engines
- Spark plug listing is taken from FAA approved data
- If you require a spark plug that is not listed, please call Univair at 1-888-433-5433 for price and availability.



Champion Spark Plug Prices

3/4" x 20		5/8" x 24	
RHB32E	\$38.93	REJ38	\$63.00
RHB37E	\$37.73	REM37BY	\$41.93
RHM38E	\$41.33	REM38E	\$37.73
RHM40E	\$41.33	REM40E	\$38.93

Aircraft	Engine	# Per Engine	Champion Spark Plugs		AC and Auburn Spark Plugs (No Longer Available)	
			3/4" x 20	5/8" x 24	3/4" x 20	5/8" x 24
■ AERONCA / CHAMPION / DECATHLON / SCOUT						
7AC, S7AC	- Continental A-65 (65hp)	- 8	- RHM40E	- REM40E /REM37BY	- HSR88	A88 SR88
7DC, S7DC	- Continental C-85-8 (85hp)	- 8	- RHM40E	- REM40E /REM37BY	- HSR88	A88 SR88
S7CCM, 7EC, S7EC, 7FC, 7JC	- Continental C-90-12 (90hp)	- 8	- RHM40E	- REM40E /REM37BY	- HSR88	A88 SR88
7GC, 7HC	- Lycoming O-290-D (135hp)	- 8	RHM40E RHM40E	- REM40E	HSR88 HSR87	SR88 SR87
7GCA, 7GCB, 7GCBA, 7GCAA, 7GCBC, 7KC	- Lycoming O-320-A (150hp)	8 -	RHM40E RHM40E	- REM40E	HSR88 HSR87	SR88 SR87
7ACA	Franklin 2A-120-B	4	RHB32E	-	-	-
7ECA	- Lycoming O-235-C (108hp) - Continental O-200 (100hp) Lycoming O-235-K (118hp)	- 8 - 8 8	RHM40E RHM40E RHM40E RHM40E RHM38E	- REM40E - REM40E REM38E /REM37BY	HSR88 HSR87 - HSR88 HSR86	SR88 SR87 A88 SR88 SR86
7KCAB	Lycoming IO-320-E (150hp) AEIO-320-E (150hp)	8 -	RHM40E RHM40E	- REM40E	HSR88 HSR88	SR88 SR88
8GCBC Super Scout	- Lycoming O-360-C Series (180hp)	- 8	RHM40E RHM38E	REM40E REM38E	HSR88 HSR87	SR88 SR87
8KCAB	- Lycoming AEIO-360-HIA (180hp) Lycoming IO-320-E (150hp) Lycoming AEIO-320-E (150hp)	- 8 - 8	RHM40E RHM38E RHM40E RHM40E	REM40E REM38E - REM40E	- HSR88 HSR88 HSR88	- SR88 SR88 SR88
■ BELLANCA						
14-13 Series	Franklin 6A4-150 (150hp) Franklin 6A4-165 (165hp)	12 -	- -	REJ38 REJ38	- -	- A44*
14-19	- Lycoming O-435-A (190hp)	- 12	RHM40E RHM40E	- REM40E	HSR88 HSR87	SR88 SR87
14-19-3, 14-19-3A, 260B	Continental IO-470-F (260hp)	12	RHB32E	-	-	-
■ CESSNA						
120-140	- Continental C-85 (85hp), C-90 (95hp)	- 8	- RHM40E	- REM40E /REM37BY	- HSR88	A88 SR88
150-A to 150-M	- Continental O-200-A (100hp)	- 8	- RHM40E	- REM40E /REM37BY	- HSR88	A88 SR88

Most commonly used spark plugs are shown in **BOLD**.

*A44 plug is unshielded and has no resistor.

ENGINE • FUEL SYSTEM

Auburn and Champion Spark Plug Cross Reference Chart (continued)

Most commonly used spark plugs are shown in **BOLD**.

Aircraft	Engine	# Per Engine	Champion Spark Plugs		AC and Auburn Spark Plugs (No Longer Available)	
			¾" x 20	⅝" x 24	¾" x 20	⅝" x 24
152, F152	- Lycoming O-235-L2C (110hp)	- 8 -	RHM40E RHM38E -	REM40E REM38E REM37BY	- - HSR86	- - SR86
170	- Continental O-145 (145hp)	- 12	RHM40E RHM40E	- REM40E/REM37BY	- HSR88	A88 SR88
170-A, 170-B	- Continental O-300 (145hp)	- 12	RHM40E RHM40E	- REM40E/REM37BY	- HSR88	A88 SR88
172-A to 172-H Skyhawk	- Continental O-300 (145hp)	- 12	RHM40E RHM40E	- REM40E/REM37BY	- HSR88	A88 SR88
172-I to 172-L Skyhawk	- Lycoming O-320-E (150hp)	- 8	RHM40E RHM40E	- REM40E	HSR88 HSR87	SR88 SR87
172-N, F172-N Skyhawk/100	- Lycoming O-320-H1AD (160hp)	- 8	RHM40E RHM38E	REM40E REM38E	HSR88 HSR87	SR88 SR87
172-P Skyhawk	- Lycoming O-320-D2J (160hp)	- 8	RHM40E RHM38E	REM40E REM38E	HSR88 HSR87	SR88 SR87
P172 Powermatic	- Continental G0-300-E (175hp)	- 12	RHM40E RHM38E	REM40E REM38E/REM37BY	HSR87 -	SR87 -
R172-K, FR172-K, Hawk XP	Continental IO-360-K (195hp)	12	RHM38E	REM38E	HSR86	SR86
172 RG "Cutlass RG"	- Lycoming O-360-F1AD (180hp)	- 8	RHM40E RHM38E	REM40E REM38E	HSR88 HSR87	SR88 SR87
175-A, 175-B, 175-C Skylark	- Continental G0-300-A, -C, -D, -E (175hp)	- 12	RHM40E RHM38E	REM40E REM38E/REM37BY	- HSR87	- SR87
175	Franklin 6A-335-B (180hp conversion)	12	RHB32E	-	-	-
177 Cardinal	- Lycoming O-320-E (150hp)	- 8	RHM40E RHM40E	- REM40E	HSR88 HSR87	SR88 SR87
177-A, 177-B Cardinal	- Lycoming O-360-A1F6D (180hp)	- 8	RHM40E RHM38E	REM40E REM38E	HSR88 HSR87	SR88 SR87
Cardinal RG	Lycoming IO-360-A1B60 (200hp)	8	RHM38E	REM38E	HSR86	SR86
180	- Continental O-470-A to O-470-J (225hp)	- 12	RHM40E RHM40E	- REM40E	HSR88 HSR87	SR88 SR87
180-A to 180-D	- Continental O-470-K, O-470-L (230hp)	- 12	RHM40E RHM40E	- REM40E	HSR88 HSR87	SR88 SR87
180-E, -F, -G, -H, -J	- Continental O-470-R, O-470-S (230hp)	- 12	RHM40E RHM40E	- REM40E	HSR88 HSR87	SR88 SR87
180-K	Continental O-470-U (230hp)	12	RHB32E	-	-	-
180	Continental O-470-U, SN 53087 and up (230hp)	12	RHB32E	-	-	-
182-A, 182-B, 182-C, 182-D	- Continental O-470-L (230hp)	- 12	RHM40E RHM40E	- REM40E	HSR88 HSR87	SR88 SR87
182-E to 182-P Skylane	- Continental O-470-R, O-470-S (230hp)	- 12	RHM40E RHM40E	- REM40E	HSR88 HSR87	SR88 SR87
182-Q, -R, F182-Q, -R Skylane	Continental O-470-U (230hp)	12	RHB32E	-	-	-
R182, FR182 Skylane RG	- Lycoming O-540-J3C5D (235hp)	- 12	RHM40E RHM38E	REM40E REM38E	HSR88 HSR87	SR88 SR87
182	Continental O-470-U, SN 67042 and up (230hp)	12	RHB32E	-	-	-

Auburn and Champion Spark Plug Cross Reference Chart (continued)

*Most commonly used spark plugs are shown in **BOLD**.*

Aircraft	Engine	# Per Engine	Champion Spark Plugs		AC and Auburn Spark Plugs (No Longer Available)	
			¾" x 20	⅝" x 24	¾" x 20	⅝" x 24
■ ERCOUCPE SERIES						
Aircoupe – Forney F1, F1A	- Continental C-90-16-F (95hp)	- 8	- RHM40E	- REM40E /REM37BY	- HSR88	A88 SR88
Alon – A2, A2A	- Continental C-90-16-F (95hp)	- 8	- RHM40E	- REM40E /REM37BY	- HSR88	A88 SR88
Ercoupe 415-C, -D, -CD, -E, -G	- Continental C-75, -85, -90, 0-200 (STC conversion)	- 8	- RHM40E	- REM40E /REM37BY	- HSR88	A88 SR88
Mooney M-10	- Continental C-90 (95hp)	- 8	- RHM40E	- REM40E /REM37BY	- -	A88 SR88
■ LUSCOMBE						
8 Series	- Continental C-65, C-85	- 8	- RHM40E	- REM40E /REM37BY	HSR88 -	A88 SR88
■ PIPER						
Cub J-3, J-4, J-5, PA-11, PA-17	- Continental A-65 (65hp) and C-75 (75hp)	- 8	- RHM40E	- REM40E /REM37BY	- HSR88	A88 SR88
J-3, J-4, PA-15	- Lycoming O-145 (65hp)	- 8	- RHM40E	- REM40E /REM37BY	- HSR88	A88 SR88
PA-12, PA-14, PA-16	- Lycoming O-235 (115hp)	- 8	RHM40E RHM40E	- REM40E	HSR88 HSR87	SR88 SR87
Super Cub PA-18 "95"	- Continental C-90 (95hp)	- 8	- RHM40E	- REM40E /REM37BY	- HSR88	A88 SR88
PA-18 "105"	- Lycoming O-235 (105hp)	- 8	RHM40E RHM40E	- REM40E	HSR88 HSR87	SR88 SR87
PA-18 "125"	- Lycoming O-290-D (125hp)	- 8	RHM40E RHM40E	- REM40E	HSR88 HSR87	SR88 SR87
PA-18 "135"	- Lycoming O-290-D2 (135hp)	- 8	RHM40E RHM40E	- REM40E	HSR88 HSR87	SR88 SR87
PA-18 "150"	- Lycoming O-320-A (150hp)	- 8	RHM40E RHM40E	- REM40E	HSR88 HSR87	SR88 SR87
Pacer PA-20 "115"	- Lycoming O-235-C (115hp)	- 8	RHM40E RHM40E	- REM40E	HSR88 HSR87	SR88 SR87
PA-20 "125"	- Lycoming O-290-D (125hp)	- 8	RHM40E RHM40E	- REM40E	HSR88 HSR87	SR88 SR87
PA-20 "135"	- Lycoming O-290-D2 (135hp)	- 8	RHM40E RHM40E	- REM40E	HSR88 HSR87	SR88 SR87
Tri-Pacer PA-22 "135"	- Lycoming O-290-D2 (135hp)	- 8	RHM40E RHM40E	- REM40E	HSR88 HSR87	SR88 SR87
PA-22 "150"	- Lycoming O-320-A (150hp)	- 8	RHM40E RHM40E	- REM40E	HSR88 HSR87	SR88 SR87
PA-22 "160"	- Lycoming O-320-B (160hp)	- 8	RHM40E RHM38E	REM40E REM38E	HSR88 HSR87	SR88 SR87
Apache PA-23 "150"	- 2/Lycoming O-320-A (150hp)	- 8	RHM40E RHM40E	- REM40E	HSR88 HSR87	SR88 SR87
PA-23 "160"	- 2/Lycoming O-320-B (160hp)	- 8	RHM40E RHM38E	REM40E REM38E	HSR88 HSR87	SR88 SR87

ENGINE • FUEL SYSTEM

Auburn and Champion Spark Plug Cross Reference Chart (continued)

Most commonly used spark plugs are shown in **BOLD**.

Aircraft	Engine	# Per Engine	Champion Spark Plugs		AC and Auburn Spark Plugs (No Longer Available)	
			¾" x 20	⅝" x 24	¾" x 20	⅝" x 24
PA-23 "235"	-	-	RHM40E	-	-	A88
	2/Lycoming O-540-B (235hp)	12	RHM40E	REM40E	HSR88	SR88
Aztec PA-23 "250"	-	-	RHM40E	REM40E	-	A88
	2/Lycoming O-540-A (250hp)	12	RHM38E	REM38E	HSR88	SR88
	-	-	-	-	HSR87	SR87
Aztec C, D, E, F PA-23 "250"	-	-	RHM40E	REM40E	HSR88	SR88
	2/Lycoming IO-540-C (250hp)	12	RHM38E	REM38E	HSR87	SR87
Aztec – Turbo-Blown	-	-	RHB37E	-	-	-
	2/Lycoming IO-540-1 (250hp)	12	-	-	-	-
Aztec C, D, E, F PA-23 "250"	-	-	RHB37E	-	-	-
	2/Lycoming TIO-540-C (250hp)	12	-	-	-	-
Comanche PA-24 "180"	-	-	RHM40E	REM40E	HSR88	SR88
	Lycoming O-360-A (180hp)	8	RHM38E	REM38E	HSR87	SR87
PA-24 "250"	-	-	RHM40E	REM40E	HSR86	SR86
	Lycoming O-540-A, IO-540-C (both 250hp)	12	RHM38E	REM38E	-	-
PA-24 "260", PA-24 B and C	-	-	-	-	-	-
	Lycoming IO-540-B, -D, -N (260hp)	12	RHM38E	REM38E	HSR86	SR86
PA-24 "260" Turbo	-	-	RHB37E	-	-	-
	Lycoming IO-540-R1A5 (260hp)	12	-	-	-	-
PA-24 "400"	Lycoming IO-720-A (400hp)	16	RHM38E	-	HSR86	SR86
Pawnee PA-25 "150"	-	-	RHM40E	-	HSR88	SR88
	Lycoming O-320-A (150hp)	8	RHM40E	REM40E	HSR87	SR87
PA-25 "235"	-	-	RHM40E	-	-	-
	Lycoming O-540-B (235hp)	12	RHM40E	REM40E	HSR88	SR88
PA-25 "260"	-	-	RHM40E	REM40E	HSR88	SR88
	Lycoming O-540-G (260hp)	12	RHM38E	REM38E	HSR87	SR87
■ STINSON						
108 Series	-	-	-	REJ38	-	-
	Franklin 6A4-150 (150hp), 6A4-165 (165hp)	12	-	-	-	A44*
108-5	Franklin 6A4-335-B1 (180hp)	12	RHB32E	-	-	-
108 Series Stinson	-	-	RHM40E	-	-	A88
	Lycoming O-435-C (190hp, STC conversion)	12	RHM40E	REM40E	HSR88/HSR87	SR88/SR87
	-	-	RHM40E	-	HSR88	SR88
	Continental O-470-A (225hp, STC conversion)	12	RHM40E	REM40E	HSR87	SR87
	-	-	RHM40E	-	HSR88	SR88
	Lycoming O-360-A1A (180hp, STC conversion)	8	RHM38E	REM38E	HSR87	SR87
Lycoming IO-360-A1A (200hp, STC conversion)	8	RHM38E	REM38E	HSR86	SR86	
■ TAYLORCRAFT						
B Series	-	-	-	-	-	A88
	Continental C-65 (65hp)	8	RHM40E	REM40E/REM37BY	HSR88	SR88
F-19	-	-	RHM40E	-	-	A88
	Continental O-200 (100hp)	8	RHM40E	REM40E/REM37BY	HSR88	SR88

*A44 plug is unshielded and has no resistor.

Throttle Controls

A-700 Button Lock Dash Control with Solid Wire End

Provides a 10-lb locking force for light and medium service applications. Black anodized aluminum knob with aluminum release button. Manufactured with .062 inch diameter stainless steel wire core in flexible metal casing. May be shortened as required. Maximum travel: 3"



44" Control (Black)	A700-10-0440	\$73.78
48" Control (Black)	A700-10-0480	\$70.59
60" Control (Black)	A700-10-0600	\$71.79
72" Control (Black)	A700-10-0720	\$60.23
60" Control (Red).....	A700-20-0600	\$71.79
72" Control (Red).....	A700-20-0720	\$60.23

A-730 Push-Pull Control with Solid Wire End

Basic push-pull control and glide-free action, with solid wire end. Ideal for cabin and carburetor heat, or fresh air controls. May be cut to the specific length you require for your particular application.



60" Control (Black)	A730-10-0600.....	\$39.21
60" Control (Red).....	A730-20-0600.....	\$39.21
72" Control (Black)	A730-10-0720.....	\$36.58
90" Control (Black)	A730-10-0900	\$41.51
144" Control (Black)	A730-10-1440	\$50.55

A-740 Ratchet Control with Solid Wire End

Ratchet design provides detented positions under vibration conditions. Simple push-pull operation. The .050 inch diameter straight wire end may be shortened as required. A special coiled wire end for easy attachment is also available. Maximum travel: 3 inches



60" Control (Black)	A740-10-0600	\$41.44
72" Control (Black)	A740-10-0720	\$39.03
60" Control (Red).....	A740-20-0600	\$41.44
72" Control (Red).....	A740-20-0720	\$39.03

A-790 Vernier Control with Solid Wire End

The A-790 control has a .078 inch diameter stainless steel wire core. Both the wire core and the flexible steel casing may be shortened as required.



60" Control (Black)	A790-10-0600.....	\$91.14
72" Control (Black)	A790-10-0720.....	\$93.13
48" Control (Red).....	A790-20-0480.....	\$89.25
60" Control (Red).....	A790-20-0600	\$91.14
72" Control (Red).....	A790-20-0720	\$93.13

A-750 Vernier Control with 10-32 Threaded End

Has 10-32 threaded shaft for use with ball joint or AN665-21R threaded terminal. Ball-socket construction lets the threaded end swivel 8° in any direction. Measured from under panel nut to end of threaded shaft with knob pushed in.



28¾" Control (Blue)	A750-30-0287	\$100.09
29" Control (Black)	A750-10-0290	\$100.09
33" Control (Black)	A750-10-0330	\$100.09
35¾" Control (Black)	A750-10-0357	CALL
44" Control (Black)	A750-10-0440	\$104.89
48" Control (Black)	A750-10-0480	\$104.89
48" Control (Red).....	A750-20-0480	\$92.48
48" Control (Blue).....	A750-30-0480	\$104.89
52¾" Control (Black)	A750-10-0526	\$103.98
60" Control (Black)	A750-10-0600	\$103.98
60" Control (Red).....	A750-20-0600	\$103.98
60" Control (Blue).....	A750-30-0600	\$103.98
72" Control (Black)	A750-10-0720	\$105.95
72" Control (Red).....	A750-20-0720	\$105.95

A-800 Friction Lock Control with 10-32 Threaded End

A fine quality control made to exacting aircraft standards. Provides positive lock throughout selected power setting by turning the chrome collect locking nut. Unique ball-socket construction permits the 10-32 threaded end to swivel 8° in any direction. Maximum travel: 3½ inches.



33" Control (Black)	A800-10-0330	\$101.53
35¾" Control (Black)	A800-10-0357	CALL
37¾" Control (Black)	A800-10-0373	\$93.74
42" Control (Black)	A800-10-0420	\$110.17
48" Control (Black)	A800-10-0480	\$84.92
52¾" Control (Black)	A800-10-0526	\$103.32
60" Control (Black)	A800-10-0600	\$86.67
72" Control (Black)	A800-10-0720	\$97.71
48" Control (Red).....	A800-20-0480	\$93.74

A-920 Push-Pull Controls for Quadrants

Push-pull controls with flexible metal casings designed for use with throttle quadrants. 10-32 threaded ends with 8° swivel, 3½ inch stroke.

72" Control (no knob).....	A920-0720	\$63.78
----------------------------	-----------------	----------------

A-970 Vernier Control with ¼-28 Threaded End

The A-970 control is similar to the Model A-750 but with ¼-28 threaded end (non-swiveling). Black is the only color of knob stocked. Measurement taken from under panel nut end of threaded shaft with knob pushed in.



40" Control (Black)	A970-10-0400	\$112.46
48" Control (Black)	A970-10-0480	\$103.17
60" Control (Black)	A970-10-0600	\$105.10
72" Control (Black)	A970-10-0720	\$107.09